

Assembly- and Operating Instructions:

3-jaw centric grippers, pneumatically actuated **RZP / RZP-A**

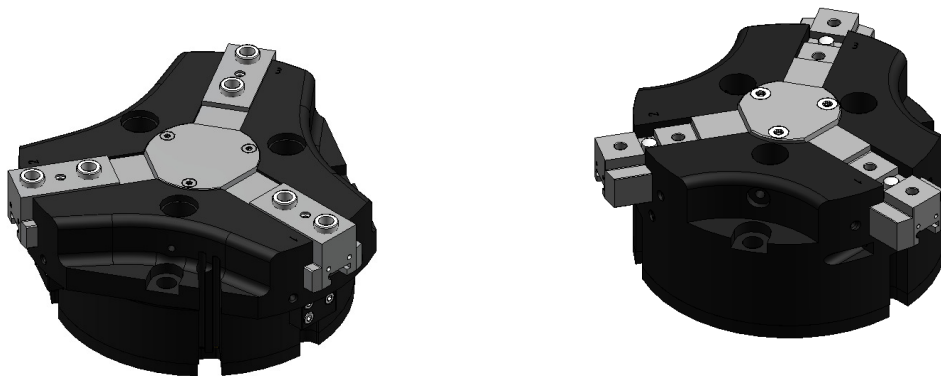

Description	Page
Comparison: RZP/ RZP-A	2
Overview: RZP/ RZP-A	4
Safety Precautions and Guidelines for Use	6
Description of the Centric Grippers: RZP	9
Description of the Centric Grippers: RZP-A	19
Installation, Commissioning: RZP/ RZP-A	28
Maintenance, Repair: RZP/ RZP-A	34
Accessories: RZP/ RZP-A	37
Declaration of incorporation: RZP/ RZP-A	39

Date of issue: Dillingen, 27.03.2014

Comparison: RZP; RZP-A

3-jaw centric grippers

3-jaw centric grippers, pneumatically actuated

RZP

Functional principle

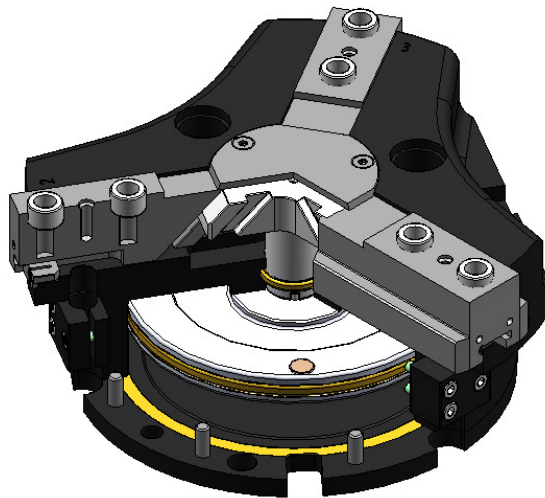

- Tried-and-tested T-slots for gripping under maximum load
- Suitable for quick and efficient gripping
- Central gripping of round and angular workpieces
- Universal use by using different clamping jaws
- Optimum use in series production
- All sizes are available with two stroke lengths
- Clamping force regulation by means of pressure change
- Constant clamping force at the same pressure, and therefore high clamping precision
- Compact, ergonomic form
- Purge port to prevent contamination
- Grippers can be installed on one gripper side
- Position polling possible by means of inductive and magnetic sensors
- Compressed air port via screw connection or direct port
- Gripping force lock for outer or inner gripping as extra type
- Base jaw / top jaw interface with centring sleeves

Comparison: RZP; RZP-A

3-jaw centric grippers

3-jaw centric grippers, pneumatically actuated

RZP-A

Functional principle

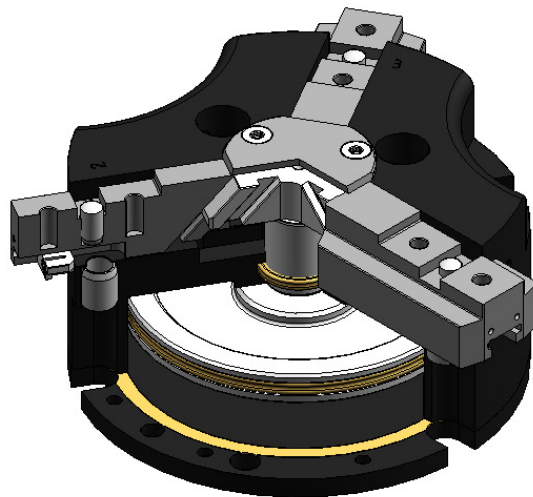

- Tried-and-tested T-slots for gripping under maximum load
- Suitable for quick and efficient gripping
- Central gripping of round and angular workpieces
- Universal use by using different clamping jaws
- Optimum use in series production
- All sizes are available with two stroke lengths
- Clamping force regulation by means of pressure change
- Constant clamping force at the same pressure, and therefore high clamping precision
- Compact, ergonomic form
- Purge port to prevent contamination
- Grippers can be installed on one gripper side
- Position polling possible by means of inductive sensors
- Compressed air port via screw connection or direct port
- Gripping force lock for outer or inner gripping as extra type
- Base jaw / top jaw interface with T-slot, positioning pin and positioning hole

Overview: RZP; RZP-A

3-jaw centric grippers

Overview: RZP



Designation	Jaw Movement [mm]		Max. possible gripping force [N]		Recommended workpiece weight [kg]	
	1	2	1	2	1	2
RZP 64	6	3	650	1200	3,2	6
RZP 80	8	4	1200	2400	6	12
RZP 100	10	5	2000	4000	10	20
RZP 125	13	6	3200	6000	16	30
RZP 160	16	8	6000	11000	30	55
RZP 200	25	14	7500	12500	37	62
RZP 240	30	17	10500	18000	53	90
RZP 300	35	20	16000	28000	80	140

RZP type:

- 1 Large jaw stroke, normal gripping force
- 2 Normal jaw stroke, high gripping force
- GA Gripping force lock for outer gripping with integrated springs for increased gripping forces
- GI Gripping force lock for inner gripping with integrated springs for increased gripping forces

Overview: RZP; RZP-A

3-jaw centric grippers

Overview: RZP-A

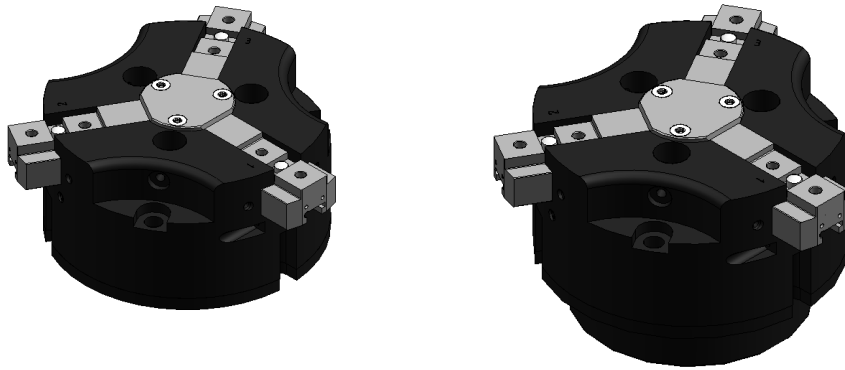

Designation	Jaw Movement [mm]		Max. possible gripping force [N]		Recommended workpiece weight [kg]	
	1	2	1	2	1	2
RZP-A 64	6	3	700	1350	3,5	6,5
RZP-A 80	8	4	1000	2500	5	12
RZP-A 100	10	5	2000	4000	10	20
RZP-A 125	13	6	3300	6500	16	32
RZP-A 160	16	8	6000	12000	30	60

RZP-A type:

- 1 Large jaw stroke, normal gripping force
- 2 Normal jaw stroke, high gripping force
- GA Gripping force lock for outer gripping with integrated springs for increased gripping forces
- GI Gripping force lock for inner gripping with integrated springs for increased gripping forces

3-jaw centric grippers

I. Qualifications of the operator

Persons with no experience in working with gripping installations are exposed to particular danger due to incorrect behaviour, particularly during set-up work due to the gripping movements and forces occurring. Gripping installations may therefore only be operated, adjusted or repaired by persons specifically qualified or trained for this work, or who have many years of experience in this work.

II. Risk of injury

For technical reasons, this unit may consist partly of sharp-edged individual parts. Particular care must therefore be taken to avoid injury when working on these parts!

1. Installed energy accumulators

Moving parts preloaded with compression springs, tension springs or with other elastic elements represent a hazard potential due to their stored energy. Underestimating this potential can result in serious injuries due to projectile-like individual parts flying around uncontrolled. This stored energy must be relieved before further work can be carried out. Gripping installations to be dismantled must therefore be examined for such potential sources of danger using the corresponding assembly drawings.

If the relief of this stored energy cannot be carried out without danger, the dismantling may only be carried out by authorised personnel.

2. Calculation of the necessary gripping forces

If this gripping installation is intended to hold or clamp the workpiece against machining forces exerted from the outside, the machining forces involved in a given machining process must be determined and provided with a safety allowance commensurate with the calculation method and the machining operation. The gripping installation must then be able to generate at least the gripping forces calculated in this way.

3. Use of other/further clamping inserts/workpieces

The necessary minimum clamping force must always be determined when using other clamping inserts or workpieces.

1. Clamping of other/further workpieces

If special clamping sets are provided for this gripping installation (jaws, clamping inserts, systems, alignment elements, position fixators, tips, etc.), only the workpieces for which the clamping sets were designed may be clamped in the intended manner using these clamping sets. If this is not observed, insufficient clamping forces or unfavourable clamping positions may result in material damage or personal injury.

If further or similar workpieces are to be clamped with the same clamping set, written approval must therefore be obtained from the manufacturer.

4. Gripping force check

Gripping force check (general)

In accordance with standard EN 1550 § 6.2 No. d) for rotating work holding chucks which can also be applied to stationary clamping installations in this one point, static gripping force measuring instruments should be used to inspect the maintenance condition at regular intervals in accordance with the maintenance manual. This prescribes that a gripping force check should be performed after approx. 40 operating hours, irrespective of the clamping frequency.

If necessary, special clamping force measuring jaws or instruments (load cells) must be used for this.

3-jaw centric grippers

5. Strength of the workpiece to be clamped

In order to ensure reliable gripping of the workpiece with the applied load forces, the clamped material must be strong enough to withstand the gripping force.
Non-metallic materials such as plastic or rubber, etc. may only be clamped after testing and under particular observation!

6. Installation and adjustment work

During clamping or alignment movements, etc., short distances are travelled in short times, in some cases with high forces.

The drive system provided for the gripper actuation must therefore always be switched off during installation and adjustment work. If the clamping movements are essential during set-up mode, however, then for clamping strokes longer than 4 mm

- A fixed or temporarily installed workpiece holder must be installed on the device, or
 - An independently actuated holding device must be installed,
- or
- A workpiece loading aid must be provided,
- or
- The set-up operations must be performed in hydraulic, pneumatic or electric jog mode (corresponding control must be possible!).

The type of this set-up aid depends fundamentally on the machine tool employed and may have to be procured separately!

The machine owner must ensure that during the whole clamping process, any danger to persons from the movements of the clamping means is ruled out. For this reason, either 2-hand controls for actuation of the clamping movement or - even better - corresponding guards must be provided.

7. Tightening and replacement of bolts

If bolts are replaced or loosened, faulty replacement or tightening may result in dangers for persons and materials. For this reason, the tightening torque recommended by the bolt manufacturer and corresponding to the bolt grade must always be used for all mounting bolts unless expressly specified otherwise.

The following tightening torque table applies for all the standard sizes M5 - M24 for grades 8.8, 10.9 and 12.9:

Grade	M5	M6	M8	M10	M12	M14	M16	M18	M20	M22	M24	
8.8	5,5	9,5	23	46	80	130	190	270	380	510	670	Nm
10.9	8,1	13	33	65	110	180	270	380	530	720	960	Nm
12.9	9,5	16	39	78	140	220	330	450	640	860	1120	Nm

All figures in Nm

If replacing the original bolts, always use bolt grade 12.9 in case of doubt. The grade 12.9 must always be used for the mounting bolts of clamping inserts, top jaws, fixed stops, cylinder covers and comparable elements.
All mounting bolts which due to their intended use have to be frequently loosened and tightened again (e.g. due to tooling work) must be coated with lubricant (grease paste) every six months in the thread area and on the head contact surface.

3-jaw centric grippers

III. Environmental hazards

A very wide variety of different media are currently required for lubrication, cooling, etc. during operation of a clamping or gripping installation. These are generally connected to the clamping installation by pipes or hoses. The most frequently used are hydraulic oil, lubricating oil/grease and coolants. Particular attention must be paid to these media when working with the clamping installation to ensure that they do not get into the ground or water. Caution! Environmental hazard!

This applies in particular:

- During installation/removal as there may still be residues in the pipework, piston chambers or oil drain plugs,
- To porous, defective or not correctly installed gaskets,
- To lubricants that for design reasons escape or are slung out of the clamping installation during operation.

These escaping substances should therefore be collected and recycled or disposed of in accordance with the applicable regulations.

IV. Safety engineering demands on power-actuated gripping installations:

1. The gripping installation may only be moved when the clamping pressure in the gripper has been built up and clamping can be carried out in the admissible working range.
2. Clamping may only be released when the gripping installation has come to a standstill.
3. In the event of a failure of the clamping energy, a signal must be given that immediately stops the machine.
4. In the event of a failure of the clamping energy, the workpiece must remain firmly clamped.
5. In the event of an electric power failure and return, it must not be possible for the momentary switching position to change.

V. Safety precautions:

1. Do not move parts by hand when the power supply is connected and switched on.
2. Do not reach into the open mechanical elements or between the clamping jaws.
3. Disconnect the energy supplies during installation, retooling, maintenance and adjustment operations.
4. Carry out maintenance, retooling or attachment outside the danger zone.
5. During installation, connection, adjustment, commissioning and testing, measures must be taken to ensure that accidental actuation of the unit by the fitter or other persons is not possible.
6. When using all handling modules, protective guards in accordance with the EC Machinery Directive must be fitted.
7. Dangers are posed by objects falling or being slung out. Measures must be taken to prevent such falling or slinging out.
8. The service and maintenance intervals must be observed.
9. Grippers which clamp under spring load or which have a gripping force lock with springs are under spring tension. The resilient pressing star is also under spring tension. Particular care is therefore necessary during dismantling.
10. Particularly on grippers with gripping force maintenance, top jaws must be designed such that in pressure-free state, a gripper reaches one of the end positions so that no residual energy is released during changing of the top jaws.

In addition, the admissible active clearances from the corresponding tables must be observed. Furthermore, the safety and accident prevention regulations applicable at the place of operation must be observed.

Description of the RZP Centric Grippers

3-jaw centric grippers

3-jaw centric grippers, pneumatically actuated

RZP

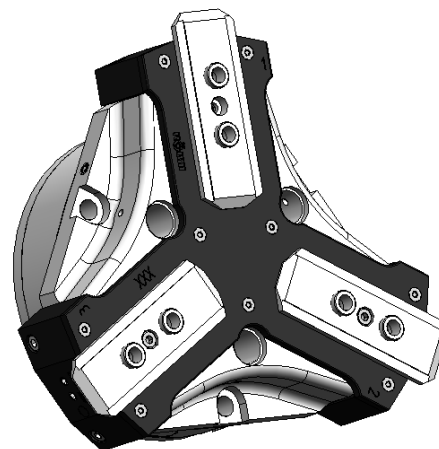
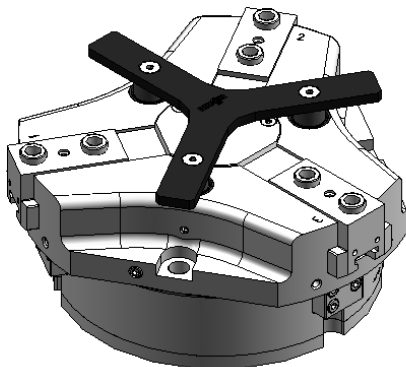

Description of the RZP Centric Grippers

3-jaw centric grippers

Description 3-jaw centric grippers: **RZP xxx/3-x**

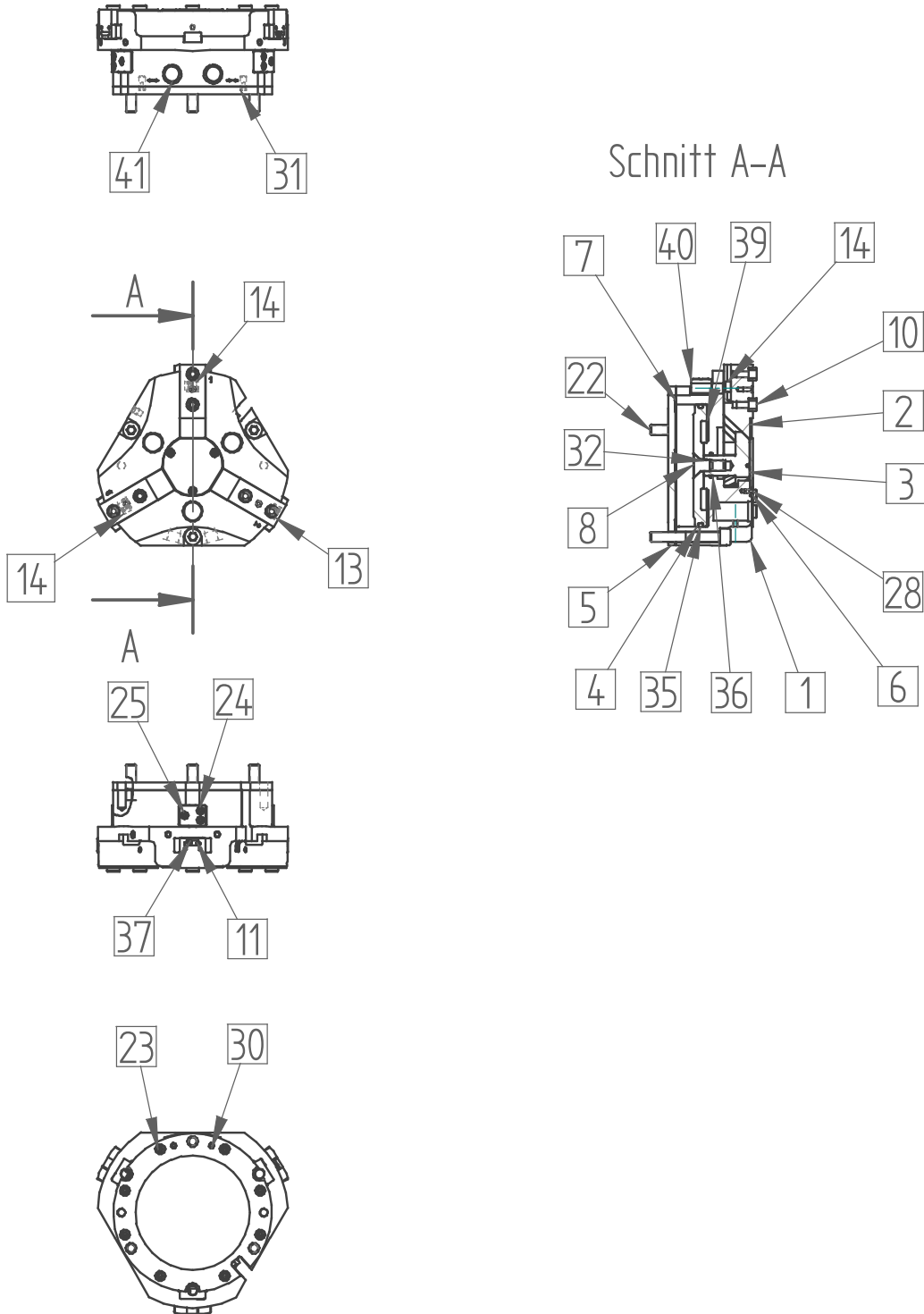

Description of the RZP Centric Grippers

3-jaw centric grippers

Description 3-jaw centric grippers: **RZP xxx/3-x**

Item	Designation	Wear part
1	Gripper body	
2	Base jaw	
3	Wedge piston	
4	Piston	
5	Flange	
6	Cover	
7	Gasket	x
8	Locating screw	
10	Centering sleeve	
11	Adjustment spindle	
13	Shifting block 1	
14	Shifting block 2	
22	Mounting bolt	
23	Mounting bolt	
24	Mounting bolt	
25	Mounting bolt	
28	Mounting bolt	
30	Grub screw DIN 913	
31	Straight pin DIN 7979	
32	Straight pin DIN 7	
35	O-ring	x
36	O-ring	x
37	Clamping bolt	
39	Round magnet	
40	Sensor holder	
41	Protective plug	

Description of the RZP Centric Grippers

3-jaw centric grippers

Description 3-jaw centric grippers: **RZP xxx/3-x /GA**

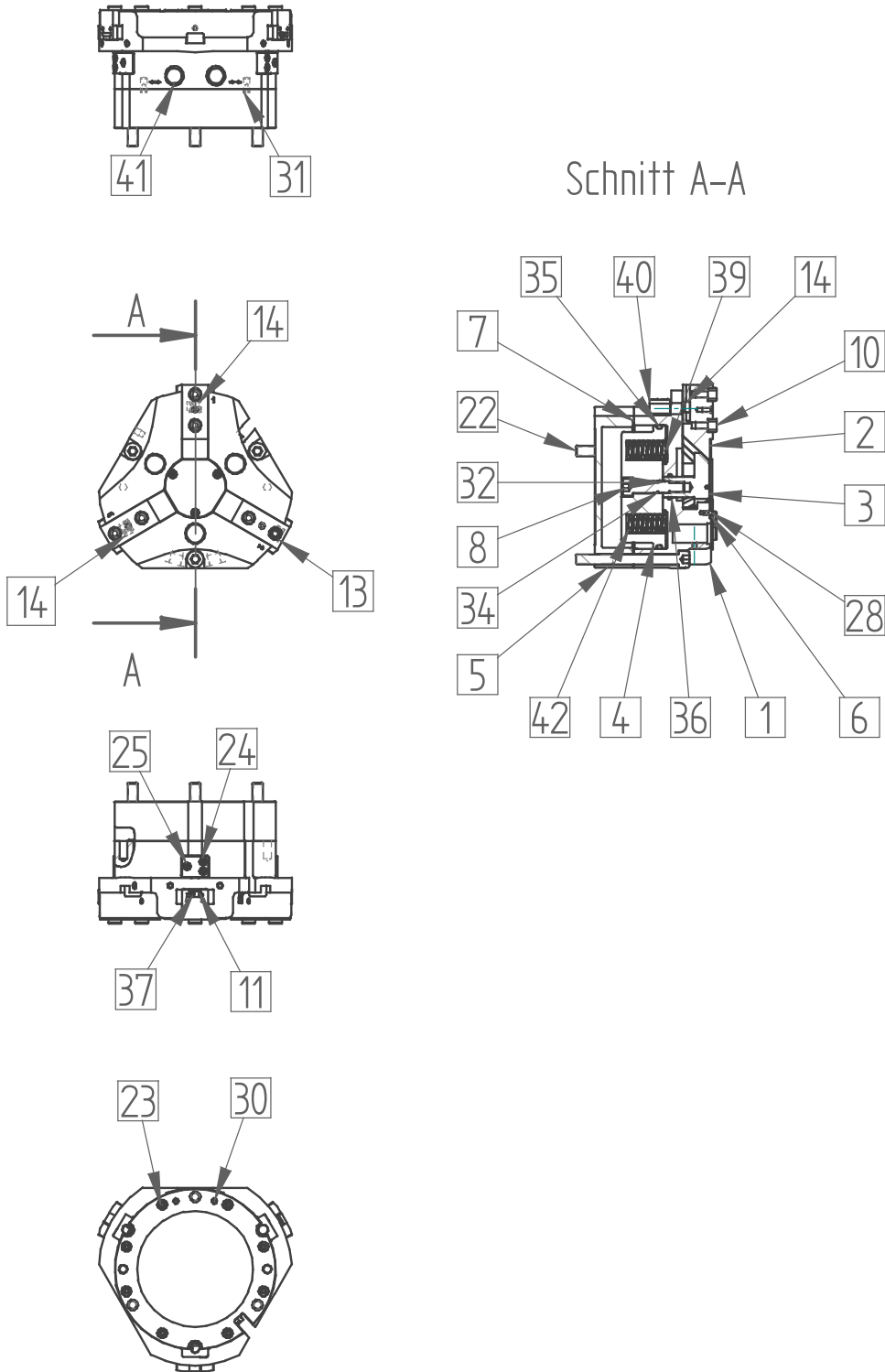

Description of the RZP Centric Grippers

3-jaw centric grippers

Description 3-jaw centric grippers: **RZP xxx/3-x /GA**

Item	Designation	Wear part
1	Gripper body	
2	Base jaw	
3	Wedge piston	
4	Piston disc	
5	Flange	
6	Cover	
7	Gasket	x
8	Locating screw	
10	Centering sleeve	
11	Adjustment spindle	
13	Shifting block 1	
14	Shifting block 2	
22	Mounting bolt	
23	Mounting bolt	
24	Mounting bolt	
25	Mounting bolt	
28	Mounting bolt	
30	Grub screw DIN 913	
31	Straight pin DIN 7979	
32	Straight pin DIN 7	
34	O-ring	x
35	O-ring	x
36	O-ring	x
37	Clamping bolt	
39	Round magnet	
40	Sensor holder	
41	Protective plug	
42	Compression spring	

Description of the RZP Centric Grippers

3-jaw centric grippers

Description 3-jaw centric grippers: **RZP xxx/3-x /GI**

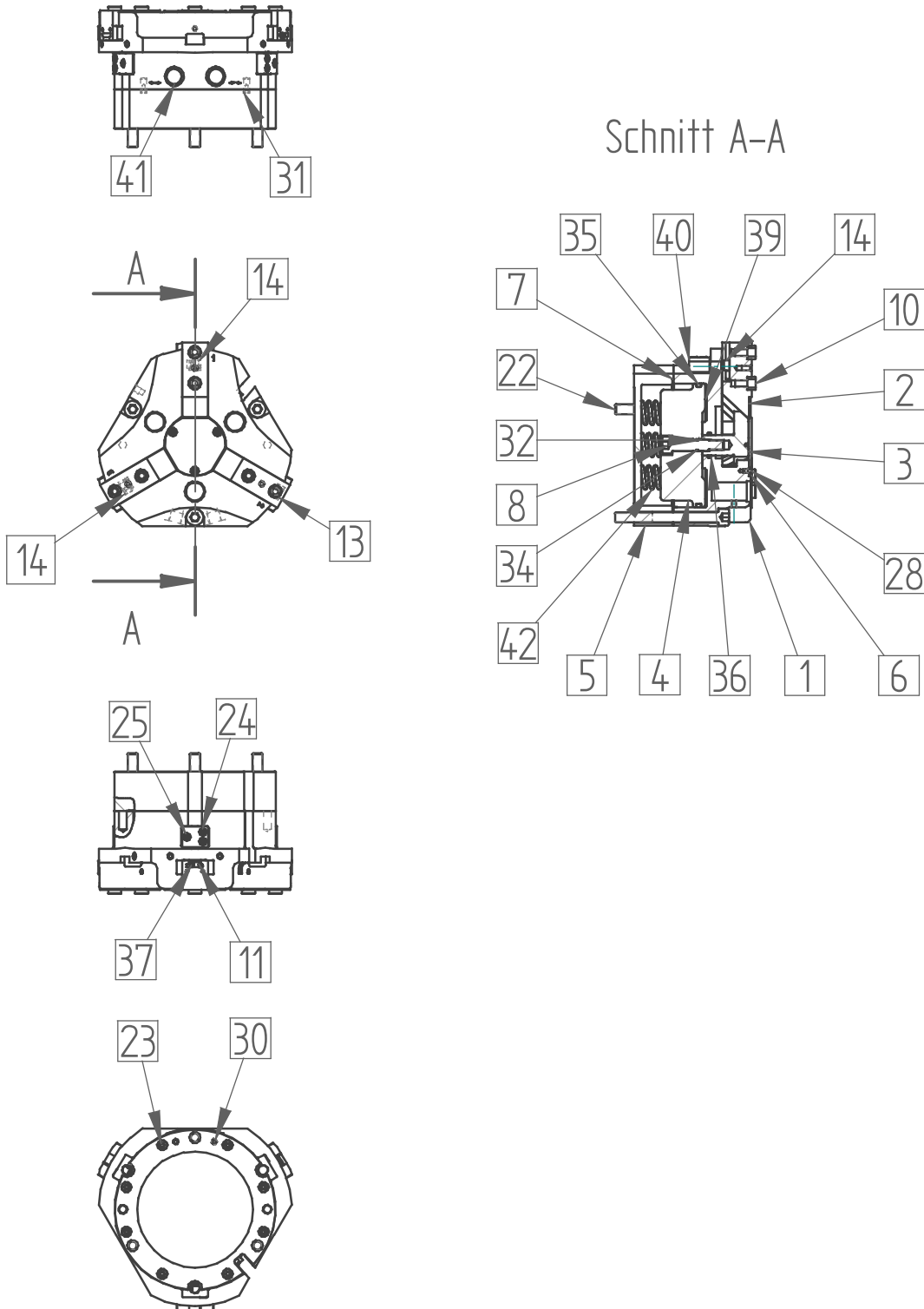

Description of the RZP Centric Grippers

3-jaw centric grippers

Description 3-jaw centric grippers: **RZP xxx/3-x /GI**

Item	Designation	Wear part
1	Gripper body	
2	Base jaw	
3	Wedge piston	
4	Piston	
5	Flange	
6	Cover	
7	Gasket	x
8	Locating screw	
10	Centering sleeve	
11	Adjustment spindle	
13	Shifting block 1	
14	Shifting block 2	
22	Mounting bolt	
23	Mounting bolt	
24	Mounting bolt	
25	Mounting bolt	
28	Mounting bolt	
30	Grub screw DIN 913	
31	Straight pin DIN 7979	
32	Straight pin DIN 7	
34	O-ring	x
35	O-ring	x
36	O-ring	x
37	Clamping bolt	
39	Round magnet	
40	Sensor holder	
41	Protective plug	
42	Compression spring	

Description of the RZP Centric Grippers

3-jaw centric grippers

Option: Dirt cover **SA-RZP**

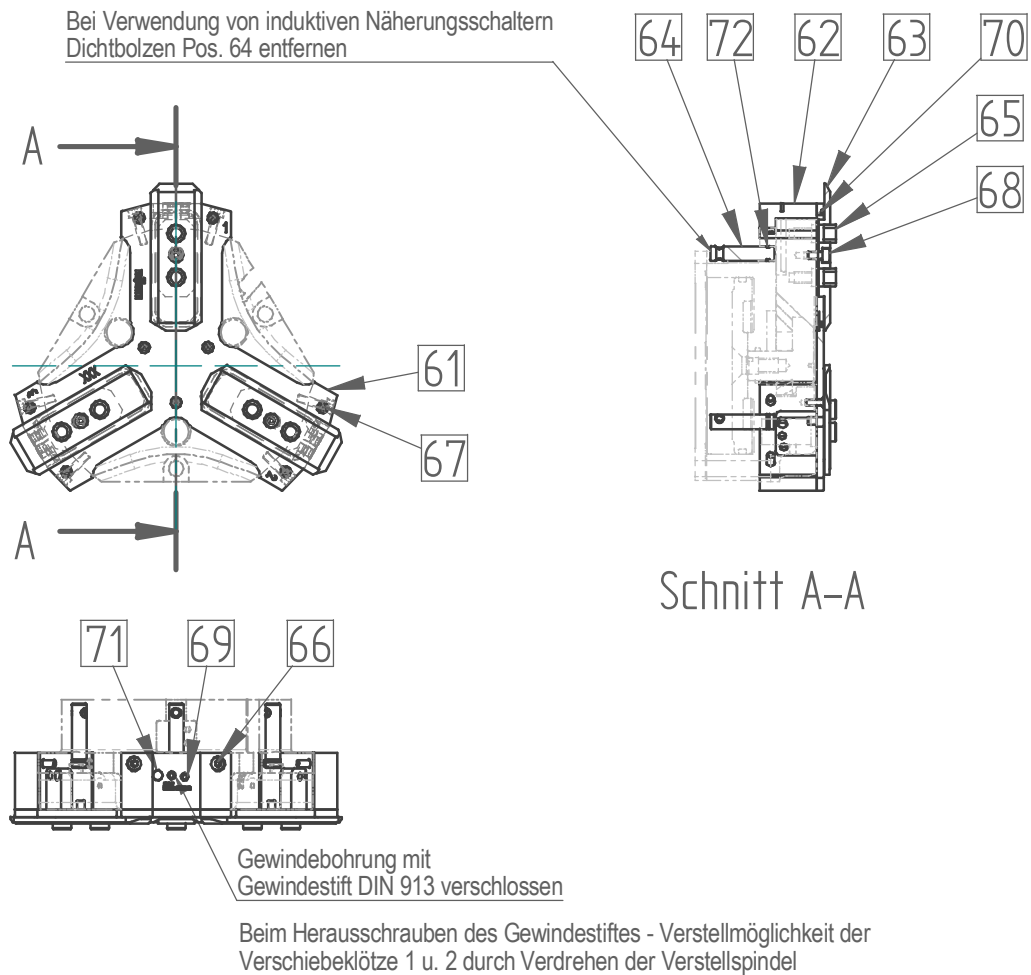

Item	Designation	Wear part
61	Cover plate	
62	Cover	
63	Intermediate jaw	
64	Sealing plug size 2	
65	Centering sleeve	
66	Mounting bolt	
67	Mounting bolt	
68	Mounting bolt	
69	Grub screw DIN 913	
70	Quad-Ring	x
71	Filter disc	
72	O-ring	x

Description of the RZP Centric Grippers

3-jaw centric grippers

Option: Resilient pressing star **RZP**

Schnitt A-A

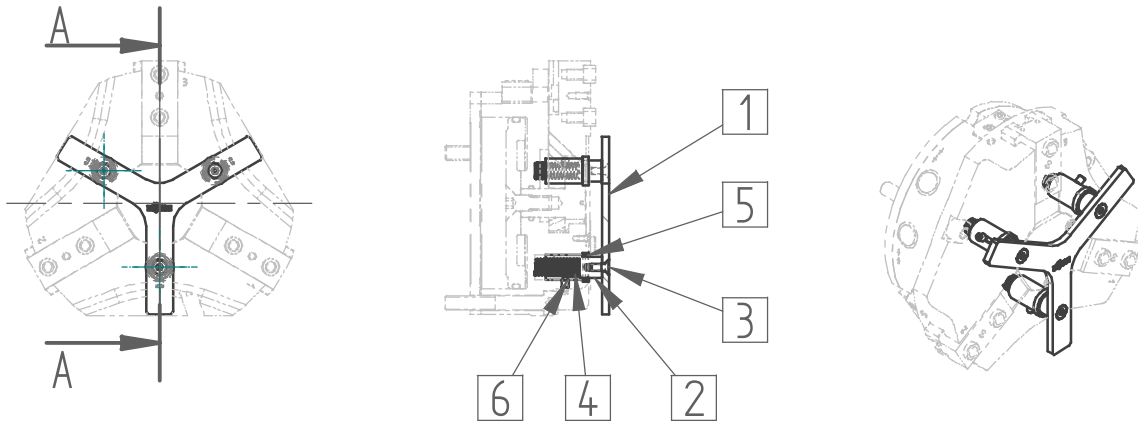

Item	Designation	Wear part
1	Pressing star	
2	Thrust bolt	
3	Countersunk-head screw DIN 7991	
4	Compression spring	x
5	Shaft seal ring	x
6	Grub screw	

Description of the RZP-A Centric Grippers

3-jaw centric grippers

3-jaw centric grippers, pneumatically actuated

RZP-A

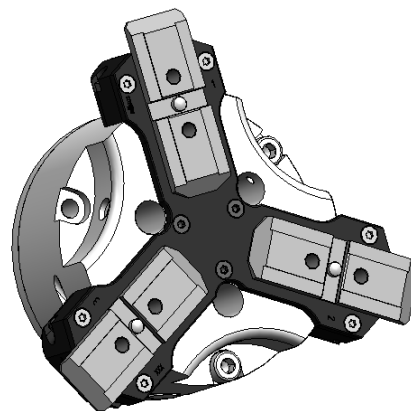
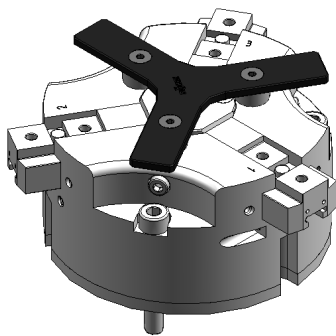
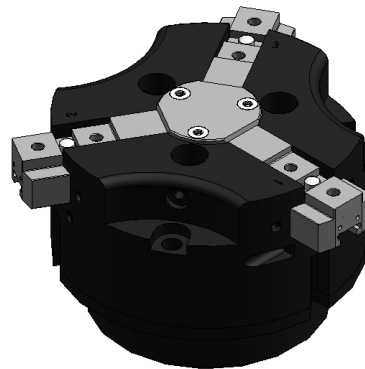
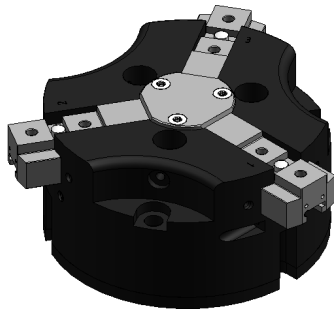

Description of the RZP-A Centric Grippers

3-jaw centric grippers

Description 3-jaw centric grippers: **RZP-A xxx/3-x**

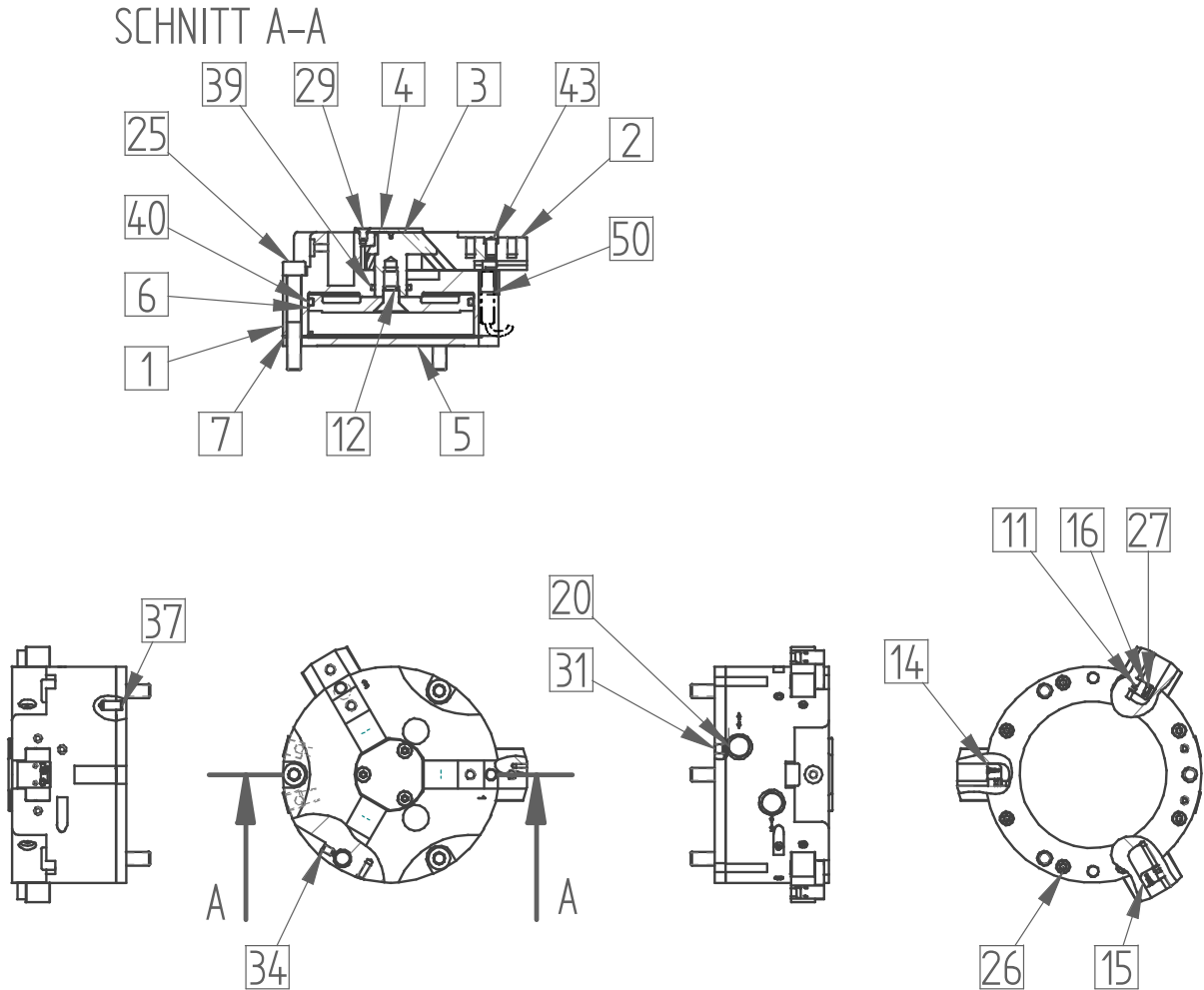

Description of the RZP-A Centric Grippers

3-jaw centric grippers

Description 3-jaw centric grippers: **RZP-A xxx/3-x**

Item	Designation	Wear part
1	Gripper body	
2	Base jaw	
3	Wedge piston	
4	Cover	
5	Flange	
6	Piston disc	
7	Gasket	x
11	Adjustment spindle	
12	Locating screw	
14	Shifting block	
15	Shifting block	
20	Protective plug	
25	Mounting bolt	
26	Mounting bolt	
27	Clamping bolt	
29	Countersunk head screw	
31	Grub screw DIN 913	
34	Pressure screw	
37	Straight pin DIN 7979	
39	QUAD-RING	x
40	QUAD-RING	x
43	Straight pin DIN 6325	
50	Roll pin DIN 7346	

Description of the RZP-A Centric Grippers

3-jaw centric grippers

Description 3-jaw centric grippers: **RZP-A xxx/3-x /GA**

SCHNITT A-A

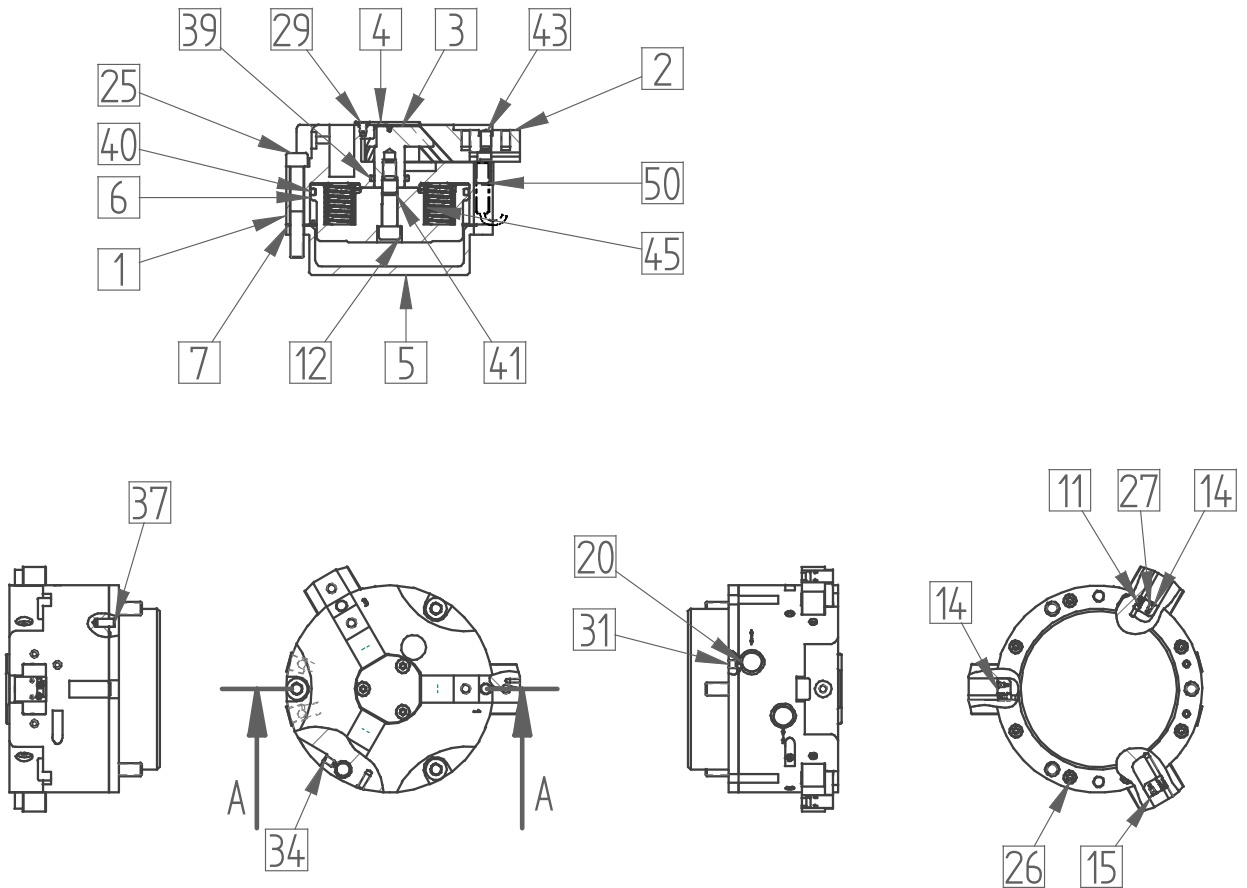

Description of the RZP-A Centric Grippers

3-jaw centric grippers

Description 3-jaw centric grippers: **RZP-A xxx/3-x /GA**

Item	Designation	Wear part
1	Gripper body	
2	Base jaw	
3	Wedge piston	
4	Cover	
5	Flange	
6	Piston disc	
7	Gasket	x
11	Adjustment spindle	
12	Locating screw	
14	Shifting block	
15	Shifting block	
20	Protective plug	
25	Mounting bolt	
26	Mounting bolt	
27	Clamping bolt	
29	Countersunk head screw	
31	Grub screw DIN 913	
34	Pressure screw	
37	Straight pin DIN 7979	
39	Quad-Ring	x
40	Quad-Ring	x
41	O-ring	x
43	Straight pin DIN 6325	
45	Compression springs	
50	Clamping sleeve	

Description of the RZP-A Centric Grippers

3-jaw centric grippers

Description 3-jaw centric grippers: **RZP-A xxx/3-x /GI**

SCHNITT A-A

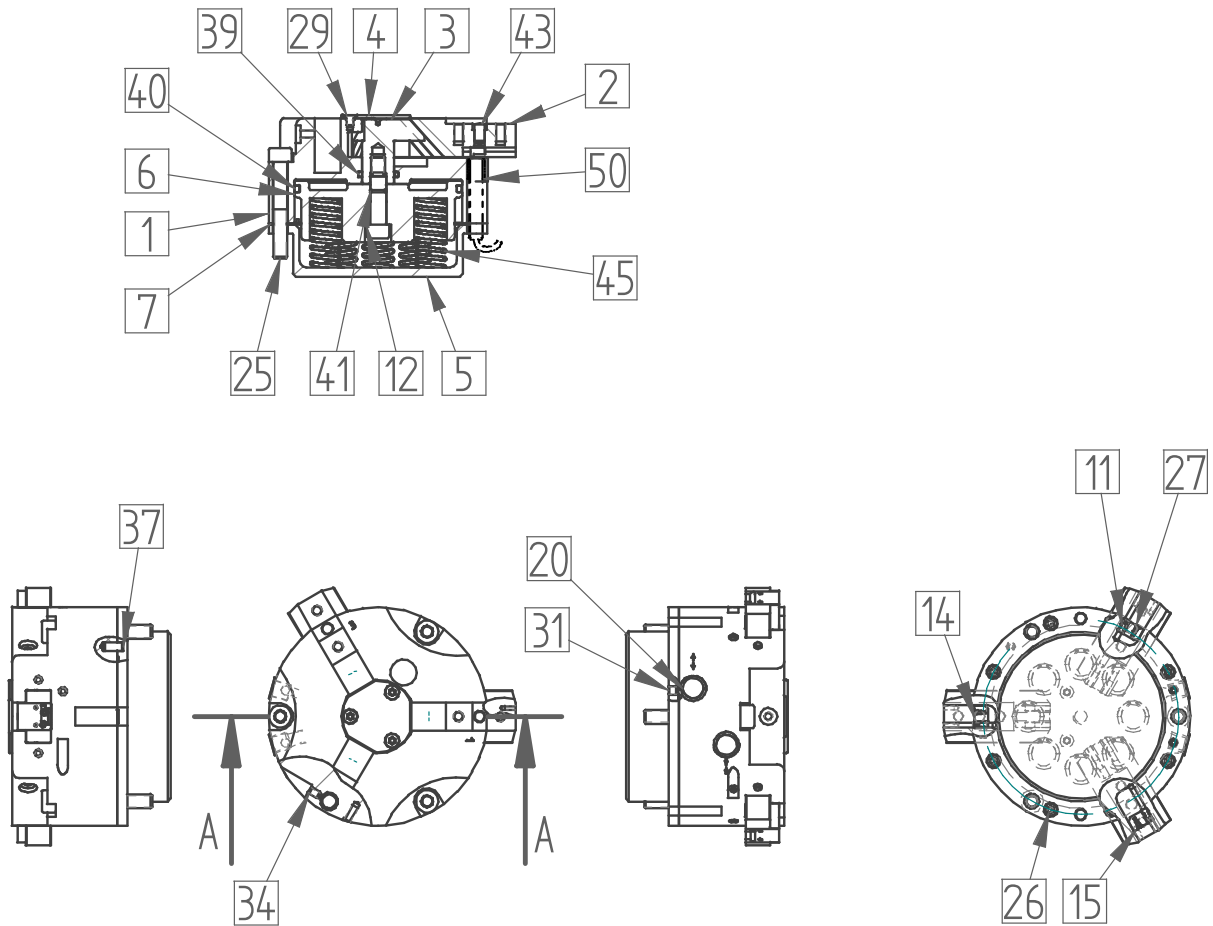

Description of the RZP-A Centric Grippers

3-jaw centric grippers

Description 3-jaw centric grippers: **RZP-A xxx/3-x /GI**

Item	Designation	Wear part
1	Gripper body	
2	Base jaw	
3	Wedge piston	
4	Cover	
5	Flange	
6	Piston disc	
7	Gasket	x
11	Adjustment spindle	
12	Locating screw	
14	Shifting block	
15	Shifting block	
20	Protective plug	
25	Mounting bolt	
26	Mounting bolt	
27	Clamping bolt	
29	Countersunk head screw	
31	Grub screw DIN 913	
34	Pressure screw	
37	Straight pin DIN 7979	
39	Quad-Ring	x
40	Quad-Ring	x
41	O-ring	x
43	Straight pin DIN 6325	
45	Compression springs	
50	Clamping sleeve	

Description of the RZP-A Centric Grippers

3-jaw centric grippers

Option: Dirt cover **SA-RZP-A**

Schnitt A-A

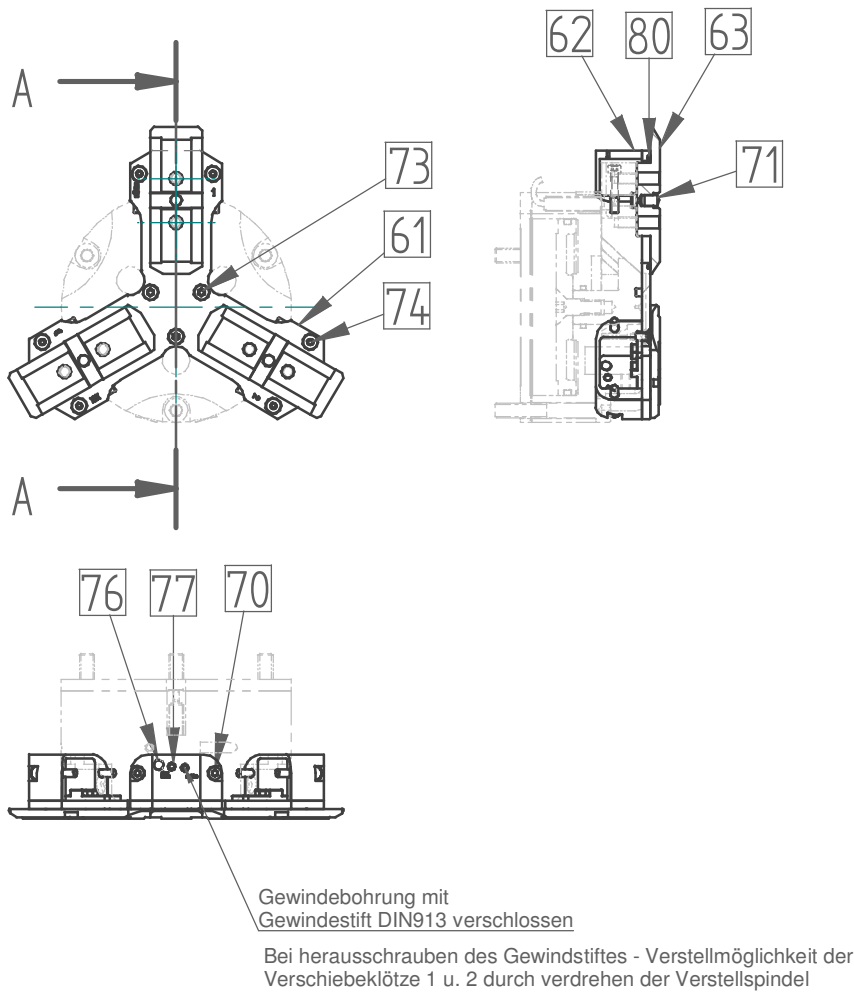

Item	Designation	Wear part
61	Cover plate	
62	Cover	
63	Intermediate jaw	
70	Mounting bolt	
71	Straight pin DIN 6325	
73	Mounting bolt	
74	Mounting bolt	
76	Filter disc	
77	Grub screw DIN 913	
80	Quad-Ring	x

Description of the RZP-A Centric Grippers

3-jaw centric grippers

Option: Resilient pressing star **RZP-A**

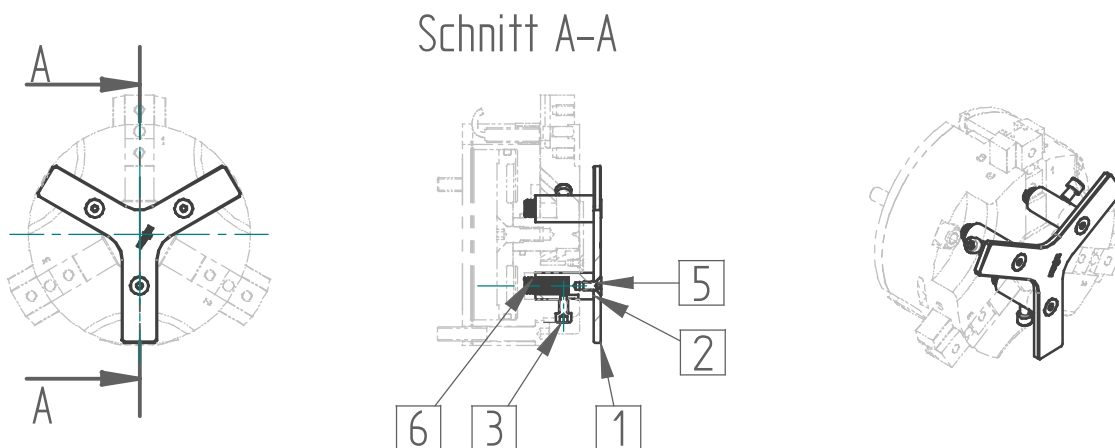

Item	Designation	Wear part
1	Pressing star	
2	Thrust bolt	
3	Fixing bolt	
5	Countersunk-head screw DIN 7991	
6	Compression spring	x

3-jaw centric grippers

RZP/ RZP-A

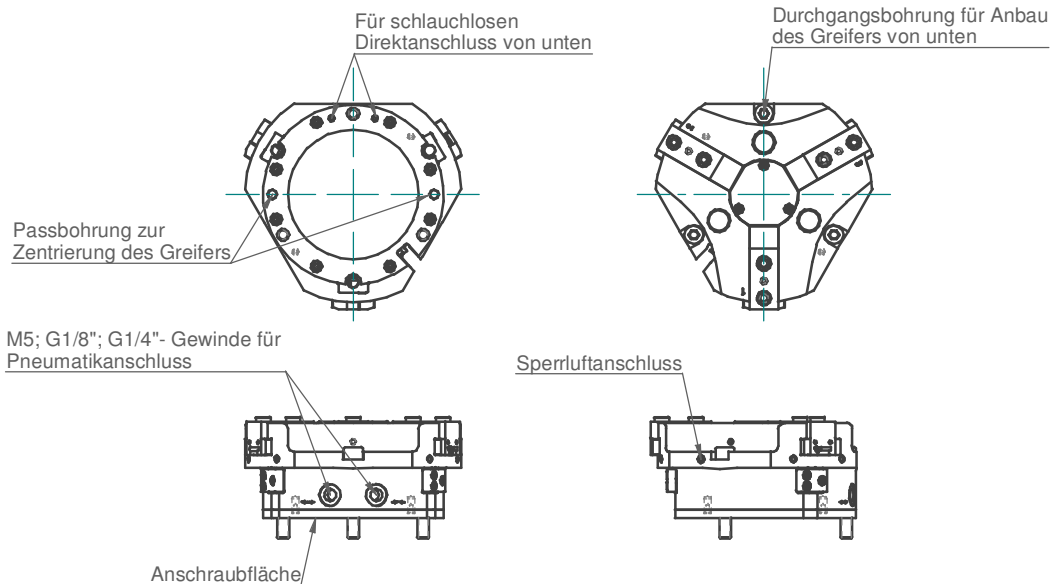

Caution: The energy supply must be switched off during installation of the gripper. Observe also the safety precautions. Please refer to the catalogue for the connection dimensions of the respective gripper size.

Installation of Gripper RZP / RZP-A

1. Position the gripper over the two positioning bores in the flange using the straight pins contained in the accessories kit.
2. Bolt on the gripper from above using 3 mounting bolts supplied.
Please observe the specified tightening torques.
3. With hoseless direct connection, pay attention to a clean connection surface. Use the corresponding gaskets from the accessories kit.
4. During installation with compressed air screw fitting, pay attention to leak tightness of the fitting.

Caution! When using hoseless direct connections, remove the grub screws and close off the ports not used using suitable blind plugs.

5. Installation and adjustment of the polling sensors.

See "Installation of the proximity sensors and magnetic switches"

Function check

1. Actuate the gripper and test the stroke end positions of the jaws.
2. Check the sensor signal.
3. Check this function also with the workpiece.

3-jaw centric grippers

RZP/ RZP-A

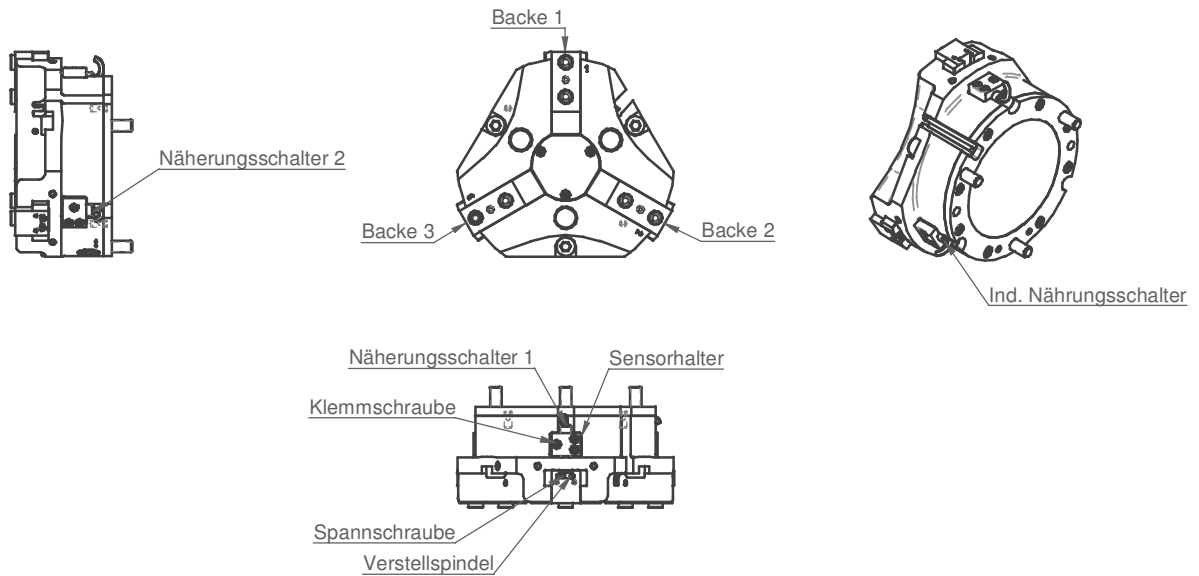

Installation of the inductive proximity switches

Poll: Gripper open

- 1) Push the proximity switch under jaw 1 or jaw 3 into the sensor holder up to the stop and secure it with the clamping screw.
- 2) Move the gripper to position "OPEN" and test the function. Works setting: "Signal". If no signal appears, a fine adjustment of the shifting block can be carried out at the adjustment spindle. The shifting block is fixed from the outside with a clamping screw. Use a screwdriver T8 (Torx size 8) for loosening and tightening.

The clamping position poll for inner gripping is adjusted to the respective workpiece using the adjustment spindle.

Poll: Grippers closed

- 1) Push the proximity switch under jaw 2 into the sensor holder up to the stop and secure it with the clamping screw.
- 2) Move the gripper to position "CLOSED" and test the function. Works setting: "Signal". If no signal appears, a fine adjustment of the shifting block can be carried out at the adjustment spindle. The shifting block is fixed from the outside with a clamping screw. Use a screwdriver T8 (Torx size 8) for loosening and tightening.

The clamping position poll for inner gripping is adjusted to the respective workpiece using the adjustment spindle.

3-jaw centric grippers

RZP/ RZP-A

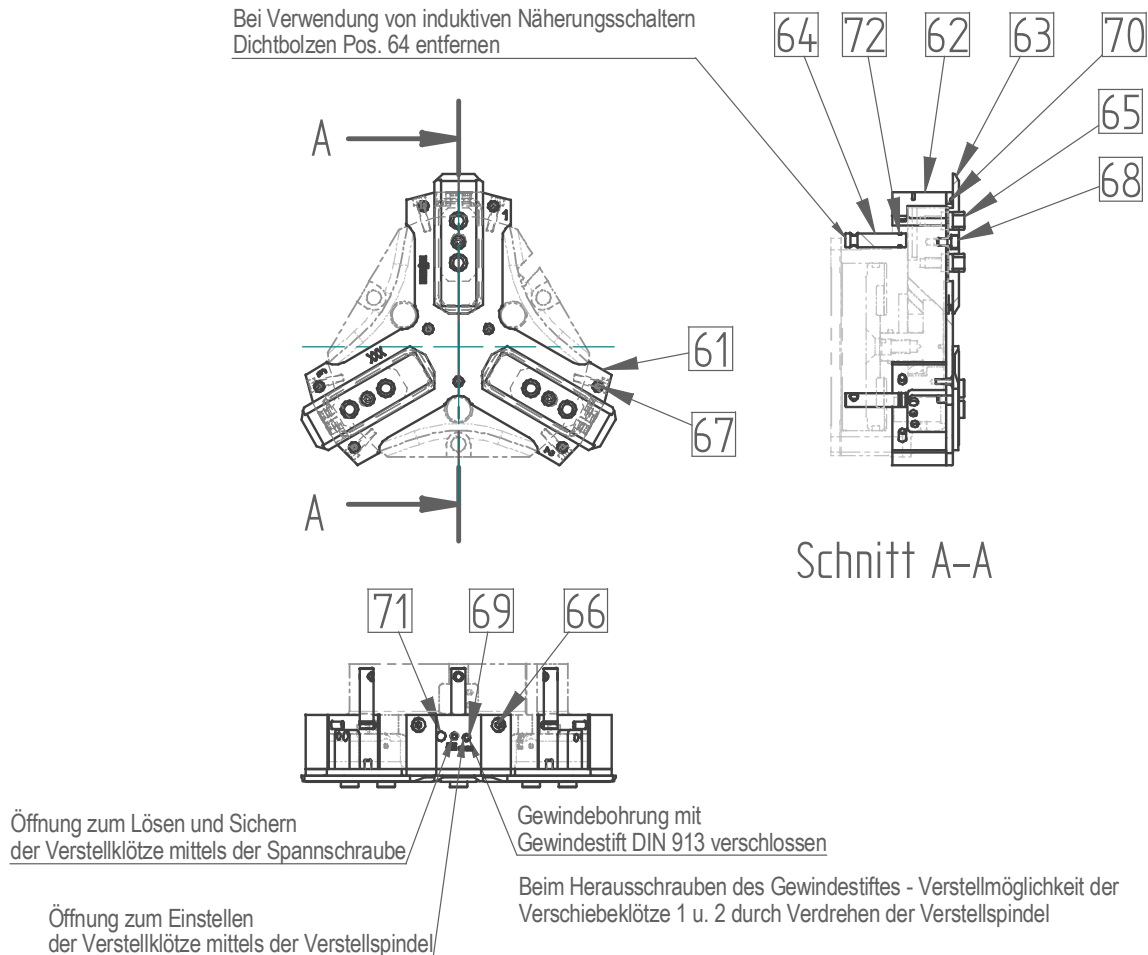

Adjustment of the sensor polling when using the dirt cover:

- 1) Remove the grub screws from the side cover
- 2) Loosen the (TORX) clamping screw 1/2 turn in the bore: "RELEASE"
- 3) Adjustment possibility for shifting blocks 1 and 2 or 3 by turning the adjustment spindle (hex. socket head screw) in bore: "ADJUST".

Caution:

The shifting blocks must not be adjusted beyond the outer edge of the base jaw as otherwise they will collide. See assembly drawing

- 4) After adjustment, the shifting block must be secured with the (TORX) clamping screw by turning 1/2 turn in bore: "SECURE".
- 5) Close off the bores in the covers with grub screws.

3-jaw centric grippers

RZP/ RZP-A

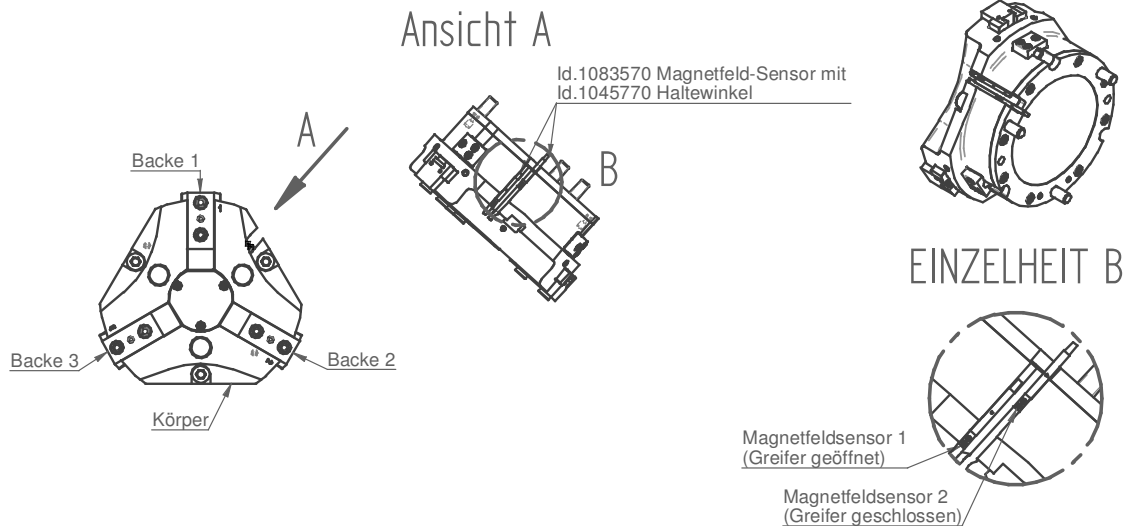

Installation of the magnetic field sensors

Poll: Gripper open

- 1) Position the gripper in position "OPEN"
- 2) Push magnetic field sensor 1 with the mounting bracket to the front into the C-groove in gripper body (item 1) up to the stop and then pull the sensor out again slowly until it switches.
- 3) Fix the magnetic switch in this position by clamping it by tightening the grub screw in the C-groove. (max. 0.1 Nm)
- 4) Test the function by opening and closing the gripper

Poll: Grippers closed

- 1) Position the gripper in position "CLOSED"
- 2) Push magnetic field sensor 2 with the mounting bracket to the front into the C-groove in gripper body (item 1) up to the stop and then pull the sensor out again slowly until it switches.
- 3) Fix the magnetic switch in this position by clamping it by tightening the grub screw in the C-groove. (max. 0.1 Nm)
- 4) Test the function by opening and closing the gripper

Poll: Workpiece gripped

Outer gripping

- 1) Clamp the part to be gripped
- Proceed as described under "Gripper closed" from points 2-4.

Inner gripping

- 2) Clamp the part to be gripped
- Proceed as described under "Gripper open" from points 2-4.

Installation, Commissioning of Centric Grippers

3-jaw centric grippers

RZP

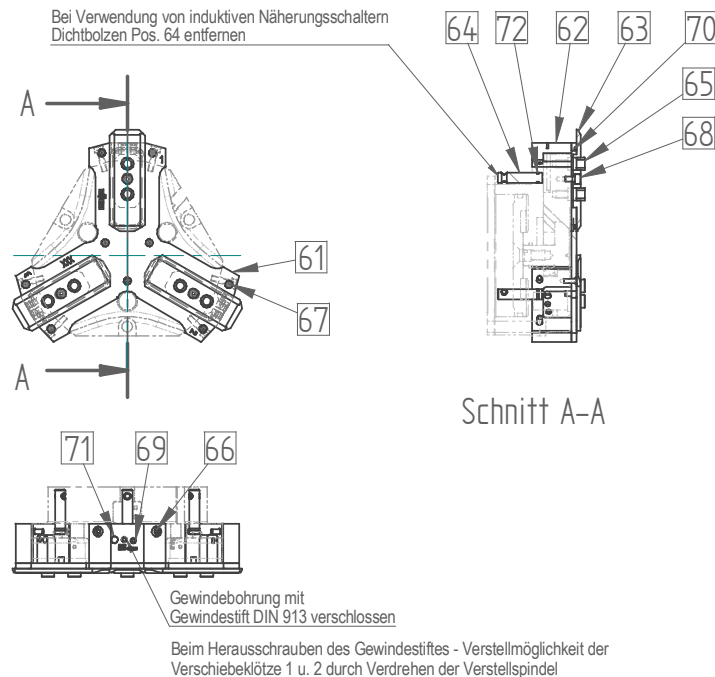

Installation of the RZP dirt cover

Caution: The energy supply must be switched off during installation of the dirt cover on the gripper. Observe also the safety precautions. Please refer to the catalogue for the connection dimensions of the respective gripper size.

- 1) Before installing the dirt cover on the RZP gripper, the lower cover must be loosened and removed from the gripper.
- 2) The connection surfaces must be clean and free from dirt.
- 3) Install the covers (item 62) on left and right on the end faces of the gripper and tighten the mounting bolts slightly.
- 4) Now place the cover plate (item 61) into the gripper and bolt this with the hexagon head bolts to the gripper and the side covers (item 62). Tighten all the mounting bolts.
- 5) Take the Quad-Ring supplied and place it into the groove of the cover plate.
- 6) Install the intermediate jaw on the base jaw. The intermediate jaw is centered on the base jaw by means of the centering sleeves. Pay attention to the clearances of the wiper surfaces on the intermediate jaw – surfaces may have different lengths. The intermediate jaw must protrude by the same amount on both sides after positioning. When the gripper is open, the overhang corresponds to the jaw stroke of the gripper. Fasten the intermediate jaw to the base jaw using cylinder screw (item 68). After installing the intermediate jaws, check the free movement of the jaws.
- 7) Install the centering sleeves on the intermediate jaw.

3-jaw centric grippers

RZP-A

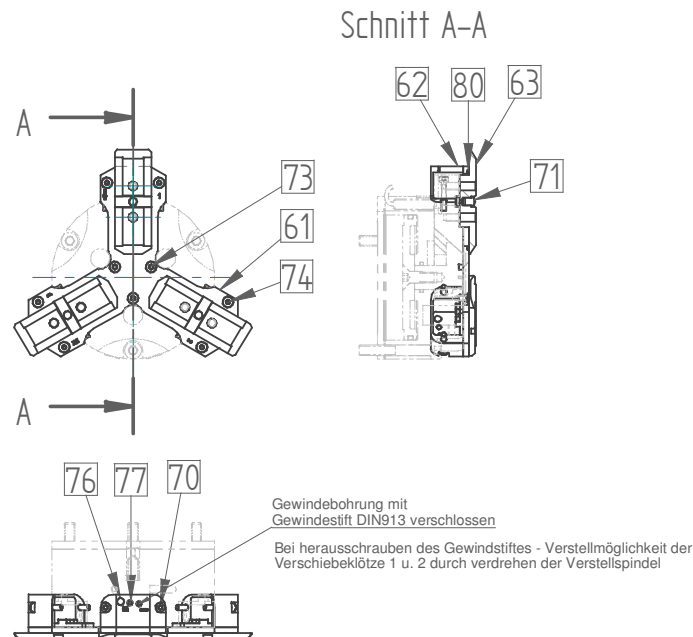

Installation of the RZP-A dirt cover

Caution: The energy supply must be switched off during installation of the dirt cover on the gripper. Observe also the safety precautions. Please refer to the catalogue for the connection dimensions of the respective gripper size.

- 1) Before installing the dirt cover on the RZP gripper, the lower cover must be loosened and removed from the gripper.
- 2) The connection surfaces must be clean and free from dirt.
- 3) Install the covers (item 62) on left and right on the end faces of the gripper and tighten the mounting bolts slightly.
- 4) Now place the cover plate (item 61) into the gripper and bolt this with the hexagon head bolts to the gripper and the side covers (item 62). Tighten all the mounting bolts.
- 5) Take the Quad-Ring supplied and place it into the groove of the cover plate.
- 6) Install the intermediate jaw on the base jaw. The intermediate jaw is positioned on the base jaw by means of the roll pin and T-slot. Pay attention to the clearances of the wiper surfaces on the intermediate jaw – surfaces may have different lengths. The intermediate jaw must protrude by the same amount on both sides after positioning. When the gripper is open, the overhang corresponds to the jaw stroke of the gripper. After installing the intermediate jaws, check the free movement of the jaws.
- 7) Install the roll pins on the intermediate jaw.

Maintenance, Repair of Centric Grippers



3-jaw centric grippers

Servicing

The maintenance free operation of the gripper is ensured for a scope of up to 10 million cycles.

The maintenance interval can be reduced by the following circumstances:

- Operation with compressed air not compliant with DIN ISO 8573-1 quality class 4
- Polluted environment
- Use other than the intended use and exceeding the gripper's capacity
- Ambient temperature higher than 60°C, lubricants harden more quickly!

The gripper must be greased with the following or a demonstrably equivalent lubricant at each maintenance interval:

- Klüberplex BEM 41-132

Depending on the load the guides in the body can also be lubricated via the lubricating nipples. The lubricating nipples can be installed instead of the barrier air connection.

Remove the threaded pins at the barrier air connections and replace with lubricating nipples.
(connection threads: M5)

Maintenance, Repair of Centric Grippers



3-jaw centric grippers

Maintenance

If the maintenance of the gripper becomes necessary (stiffness; loss of gripping force), we recommend to have the maintenance work and seal change be conducted by the RöhM GmbH Repair Service. In the event of an unauthorized disassembly and reassembly of the gripper, complications may occur, as certain work steps require special assembly equipment.

Replacing the body and the base jaws

The base jaws and the guides in the body are aligned. To replace these parts, send the complete gripper to the RöhM GmbH Repair Service with a repair order or order the body with base jaws as one unit.

Replacing the seal

It is advisable to in particular replace the dynamically loaded sealing elements and guide rings. In this case a sealing element set should always be available.

The gripper is disassembled into its individual parts for maintenance and servicing, it is then checked for wear and tear, cleaned and after defective elements have been replaced the gripper is greased and reassembled. When assembling the gripper, take care to ensure that the marked parts are placed back in the intended position.

Please be advised that only **ORIGINAL** spare parts or parts from authorized suppliers may be used. Any liability shall cease to exist for all damage caused by the use of foreign components.

<p>Important: In order to be able to handle any orders of spare parts or individual parts easily, the six-digit identification number engraved in the component and the manufacturing number - if available - have to be stated. The manufacturing number consists of two digits and a consecutive number, attached to the identification plate or in the direct vicinity of the identification number.</p>
--

Address of the manufacturer:

Company
RÖHM GmbH Werk Dillingen
RöhMstr. 6
89407 Dillingen/Donau
GERMANY

Maintenance, Repair of Centric Grippers

3-jaw centric grippers

Dismantling and assembly of a gripper:

Caution: Be sure to observe the safety precautions.

- 1) Disconnect the pressure lines
- 2) Loosen the bolts and remove the cover, item 6 (RZP) or item 4 (RZP-A).
- 3) Unscrew the bolts and remove the flange, item 5
- 4) Loosen the locating screw, item 8 (RZP) or item 12 (RZP-A) and remove the piston disc, item 4 (RZP) or item 6 (RZP-A). (The locating screw is secured with Loctite)
- 5) Press the wedge piston, item 3, up out of the gripper body, item 1.
- 6) Pull the base jaws (item 2) out of the gripper body (item 1).
- 7) Remove all gaskets
- 8) Clean all parts thoroughly and inspect the parts for wear or defects.
- 9) Renew all gaskets

The gripper is reassembled in the reverse order.

Pay attention to the correct numbering and position of the components. Unless otherwise prescribed, all bolts must be secured with Loctite 222 and tightened to a torque as specified in the DIN standard (see point II/7).

Type GA or GI with gripping force lock:

Caution! *Particular dangers exist here! Be sure to pay attention to the assembly drawing!*

Gripper body, flange, piston disc and piston may be under spring pressure. The spring load on the piston disc (GA type) or flange (GI type) must be countered by appropriate means.

Accessories (not included in scope of supply)

3-jaw centric grippers

Sensors

Inductive proximity switch

Order No. ID 229114
with 3 m cable (without plug)

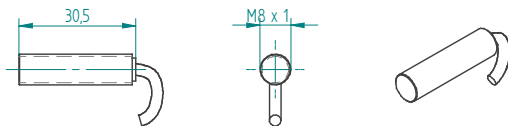

Inductive proximity switch

Order No. ID 389661
with 3 m cable (without plug)

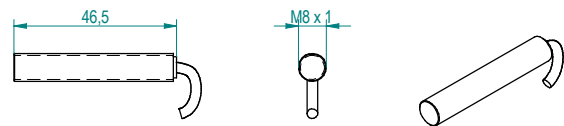

Magnetic field sensor

Order No. ID 1083570
with 3 m cable (without plug)

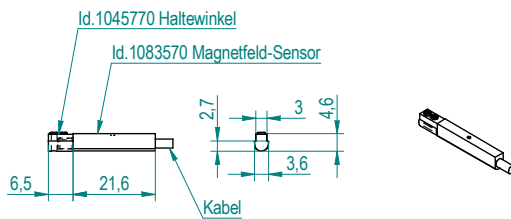

Pneumatic connections

Screw connection M5

Order No. ID 1004281

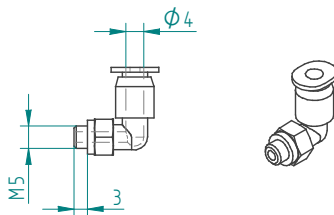

Throttle check valve M5

Order No. ID 476077

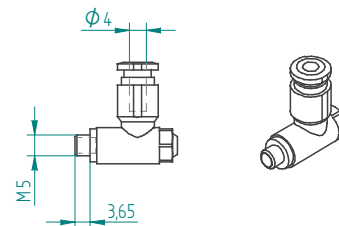

Screw connection M5

Order No. ID 476989

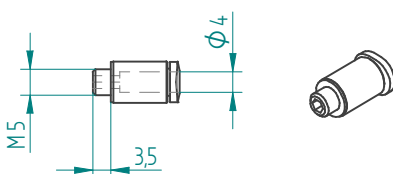

Accessories (not included in scope of supply)

3-jaw centric grippers

Screw connection G1/8"

Order No. ID 477025

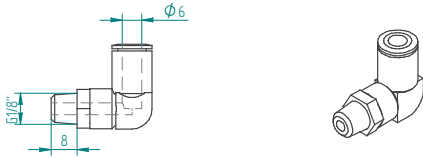

Throttle check valve G1/8"

Order No. ID 499260

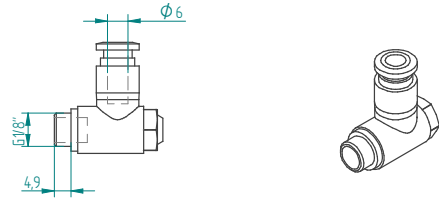

Screw connection G1/8"

Order No. ID 1111010

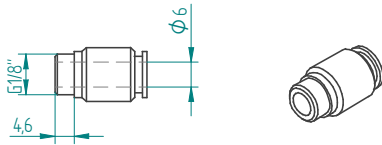

Screw connection G1/4"

Order No. ID 1002453

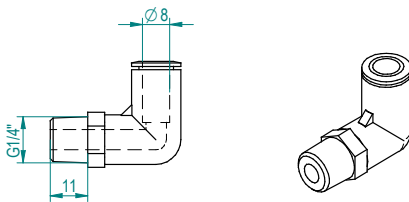

Throttle check valve G1/4"

Order No. ID 1201067

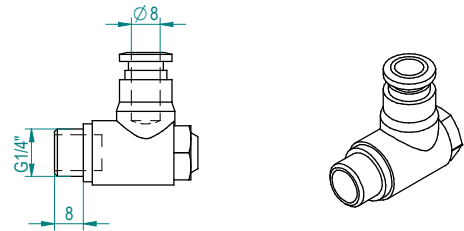

Screw connection G1/4"

Order No. ID 1028900

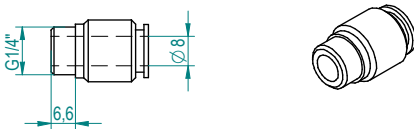

Pressure relief valve

Order No. ID 1078823

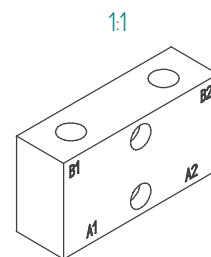
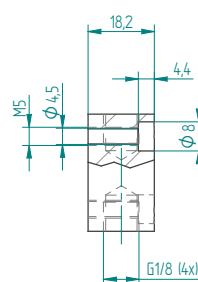
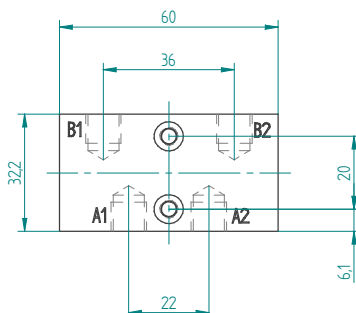



Erklärung für den Einbau einer unvollständigen Maschine

Im Sinne der Richtlinie 2006/42/EG für Maschinen, Anhang II, Teil B

Hiermit erklärt die RöhM GmbH / Werk Dillingen
RöhMstraße 6
D-89407 Dillingen/Donau
Deutschland

für folgendes Produkt:

Fabrikat: Pneum. bet. 3-Backen-Zentrischgreifer
Typenbezeichnung: RZP 64-300; RZP-A 64-160
Baujahr: ab 2014

dass die folgenden grundlegenden Anforderungen der o. g. Richtlinie - einschließlich der zum Zeitpunkt dieser Erklärung gültigen Änderungen - zur Anwendung kommen und eingehalten wurden:

EN ISO 12100-1 Sicherheit von Maschine – Grundbegriffe, allgemeine Gestaltungsleitsätze,
- Teil 1: Grundsätzliche Terminologie, Methodik

EN ISO 12100-2 Sicherheit von Maschine – Grundbegriffe, allgemeine Gestaltungsleitsätze,
- Teil 2: Technische Leitsätze und Spezifikationen

dass die speziellen technischen Unterlagen gemäß Anhang VII Teil B der o. g. Richtlinie erstellt wurden und den einzelstaatlichen Stellen auf begründetes Verlangen wie folgt übermittelt werden:

In Papierform **oder** in Dateiform per E-Mail

dass diese unvollständige Maschine erst dann in Betrieb genommen werden darf, wenn festgestellt wurde, dass die Maschine, in welche die unvollständige Maschine eingebaut werden soll, den Bestimmungen der o. g. Richtlinie entspricht.

Person, die in der Gemeinschaft ansässig und bevollmächtigt ist, die technischen Unterlagen zusammenzustellen:

Name: Wiedholz, Gerhard Anschrift: RöhM GmbH, Werk Dillingen, RöhMstr. 6, 89407 Dillingen

Ausstellungsort: Dillingen
Ausstellungsdatum: 16.01.2014
Funktion des Unterzeichners im Unternehmen: Konstruktionsleiter
Name des Unterzeichners: Gerhard Wiedholz
Unterschrift: i. V. 
RöhM GmbH
Werk Dillingen
RöhMstraße 6
89407 Dillingen/Donau
Tel. 09071/508-0