



driven by technology



Swivel Units of the Series

RSP

Röhm – Swivel Units – Pneumatically Controlled

Table of Contents:

1. Other Applicable Documents	3
2. Usage in accordance with the intended purpose	3
3. Function.....	3
4. Personnel qualifications.....	3
5. Installation	3
5.1. Information on possible dangers during the installation of the swivel unit	3
5.2. Installation of the swivel unit.....	3
5.3. Information on possible dangers during the installation of the customer-specific applications	3
5.4. Installation of the customer-specific application.....	3
6. Start-up.....	4
6.1. Information on possible dangers during start-up.....	4
6.2. Setting the end position J3 for swivel unit with 90° or 180° swivel angle (also for –MV–).....	4
6.3. Setting the end position – J90 – for swivel unit with a 180° swivel angle.....	4
6.4. Fine adjustment of the end position damping for all swivel units	4
6.5. Rough adjustment of the shock absorbers for universal swivel units.....	5
6.6. Piston chamber separation	5
6.7. Swivel unit with fluid feeder	6
6.8. Swivel units with fluid feeder and cable feed-through.....	7
7. Locked centre position.....	8
7.1. Function.....	8
7.2. Schematic.....	8
7.3. Control.....	9
7.3.1. Pneumatic connection diagram	9
7.4. Path step charts.....	10
7.4.1. Difference between 6x or alternatively 5x and 4x or alternatively 3x sensor query	10
Path step chart with 6x or alternatively 5x sensor query (RECOMMENDED)	10
Path step chart with 4x or alternatively 3x sensor query (RECOMMENDED CONDITIONALLY).....	10
7.4.2. Path step chart query using 6 or alternatively 5 sensors	11
7.4.3. Path step chart query using 4 or alternatively 3 sensors	12
7.5. Control using X7 programming module	13
7.5.1. Illustration of the programming modules as FUP.....	13
7.5.2. Explanation of the variables.....	13
7.5.3. Signal path of the module	14
7.6. Adjusting the end position of the centre position	15
7.7. Adjusting the end position damping of the centre position.....	15
8. Maintenance	16
8.1. Information on possible dangers during maintenance	16
8.2. Maintenance intervals.....	16
8.3. Dismantling the swivel unit	16
9. Fault repair	16
10. Accessories / delivery contents	17
11. Sensors	17
11.1. Information on using sensors.....	17
11.2. Setting the magnetic field sensors.....	17
11.2.1. General.....	17
11.2.2. Swivel unit with locked centre position and query using 6 magnetic field sensors.....	18
11.3. Setting the inductive sensors.....	19
12. Declaration of incorporation.....	20

1. Other Applicable Documents



The following documents are available on our homepage for downloading. Only the current documents obtained from the homepage are valid.

- Catalogue
- Drawings, performance data, information on accessories and so on
- General terms and conditions of business
- Information on the warranty among other things

2. Usage in accordance with the intended purpose



The swivel unit is only to be used in its original condition with original accessories without any unauthorised changes and within the scope of its defined usage parameters.
RÖHM GmbH is not responsible for any damage caused by improper use.

The swivel unit is designed exclusively for operation with compressed air. It is not suitable for operation with other media such as liquids or other gasses. The swivel unit is used in accordance with the intended use in closed rooms for swivelling permissible attachments or alternatively workpieces. It is not suitable for swivel workpieces during a machining process and is not suitable for direct contact with perishable goods.

3. Function

Alternate ventilating puts the two internal pneumatic pistons into motion. The energy created by this process is transferred to the driver via the steering rack shaped pistons and results in the torque.

4. Personnel qualifications

The installation, start-up and maintenance may only be carried out by trained qualified personnel. The prerequisite for this is that these persons have completely read and understood the installation and operating instructions.

5. Installation

5.1. Information on possible dangers during the installation of the swivel unit



CAUTION! Failure to heed this information may lead to minor injuries

When transporting the unit to its final destination, the locally applicable occupational safety laws concerning lifting and carrying heavy loads must be observed.



WARNING! Failure to heed this information may lead to death or serious injuries

For overhead installation of a swivel unit with deadweight of more than 3 kg, the work must be performed with a lifting mechanism or with two persons.

5.2. Installation of the swivel unit

The swivel unit can be mounted from multiple sides on a bolting surface that complies with the requirements of flatness. If the length of the bolting surface is <100 mm, then the permissible unevenness is < 0.02 mm. For a length of >100 mm, the permissible unevenness is < 0.05 mm.

The following work steps must be carried out to install the swivel unit:

- When using the hoseless connection, put O-rings in the pockets of the bolting surface that have been made by the customer.
- Put cylindrical pins or, depending on the type, centring sleeves in the fittings of the swivel unit provided for that purpose.
- Position the swivel unit on the surface by means of cylindrical pins or, depending on the type, centring sleeves.
- Secure the swivel unit with cheese head screws of strength class 8.8.

5.3. Information on possible dangers during the installation of customer-specific applications



WARNING! Failure to heed this information may lead to death or serious injuries

Before the installation of permissible attachments or alternatively workpieces, make sure the system is not pressurised and the supply lines are removed from the swivel unit.

5.4. Installation of the customer-specific application

Before installation of the customer-specific application, check its weight to make sure that it is suitable for the selected swivel unit.

The following work steps must be carried out to install the customer-specific application:

- When using the hoseless connection, put O-rings in the pockets of the driver provided for that purpose.
- Put centring sleeves in the fittings on the driver provided for that purpose.
- Position the customer-specific application by mean of centring sleeves on the driver.
- Secure the customer-specific application with cheese head screws of strength class 8.8.

6. Start-up

6.1. Information on possible dangers during start-up



The swivel unit may only be used in accordance with its purpose and technical data. The safety regulations at the place of use must be complied with. RÖHM GmbH is not responsible for any damage caused by not observing this installation and operating manual.



WARNING! Failure to heed this information may lead to death or serious injuries

Before actuation of the swivel unit, make sure that no body parts are in the positioning range of the swivel unit. The swivel unit can still move after an EMERGENCY STOP.

6.2. Setting the end position J3 for swivel unit with 90° or 180° swivel angle (also for –MV–)

The swivel unit is equipped with internal stops that allow for an adjustment of the swivel angle of +/- 3° per stop. To adjust the stops, the protective cap ① must first of all be screwed off. Afterwards, loosen the lock nuts ② and position the stop ③ while the swivel unit is not pressurised. During this setting procedure, it must be ensured at all times that the stops contact the respective faces of the steering rack. Slightly tighten the lock nuts ② and carry out a functional check. Tighten the lock nuts ② and afterwards screw on the protective cap ①.

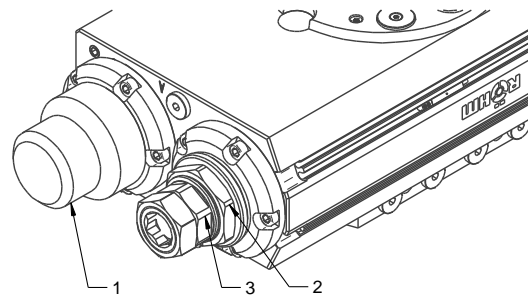

6.3. Setting the end position – J90 – for swivel unit with a 180° swivel angle

The swivel unit is equipped with internal stops that allow for an adjustment of the swivel angle from -3° to 93° or alternatively 87° to 183°. To adjust the stops, the protective cap ① must first of all be screwed off. Afterwards, loosen the lock nuts ② and position the stop ③ while the swivel unit is not pressurised. During this setting procedure, it must be ensured at all times that the stops contact the respective faces of the steering rack. Slightly tighten the lock nut ② and carry out a functional check. Tighten the lock nuts ② and afterwards screw on the protective cap ①.

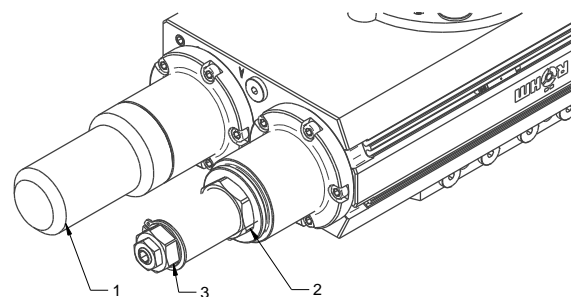

6.4. Fine adjustment of the end position damping for all swivel units



The shock absorber of swivel units with a locked centre position may only be twisted out until uniform damping of the swivel movement is ensured and no more. If this is not the case, then the warranty becomes void.

The following work steps must be carried out for fine adjustment of the end position damping.

- Screw off the protective cap ①
- Loosen the lock nuts ② of the shock absorber setting or alternatively the shock absorber for – MV – units.
- Turn the shock absorber setting, ③ or alternatively the shock absorber for – MV – units in a counter-clockwise direction (damping decreases) or alternatively twist in clockwise direction (damping increases).
- For swivel units with – MV –, the Usit ring must also be turned out or alternatively in
- For – MV – units, turn the shock absorber at most until uniform damping of the swivel motion is ensured
- Slightly tighten the lock nuts ②
- Remove people, all tools and other objects from the operating range of the swivel unit.
- Connect the swivel unit to the power supply and fill it with suitably conditioned air.
- Open the set screws of the throttle check valves by a few turns.
- Pressurise the swivel unit alternately with compressed air.
- Check the settings.
- Readjust if necessary using the set screws of the throttle check valves and by shifting the shock absorber.
- Jam the lock nut ② of the shock absorber.
- Screw on the protective cap ①

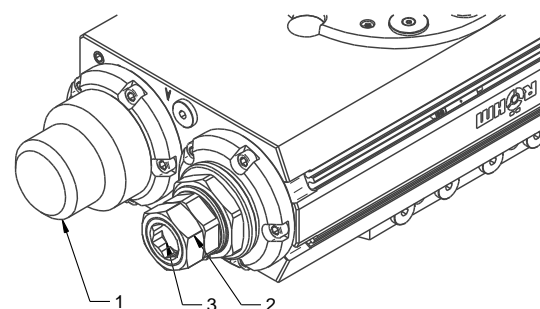

You have the ideal setting if uniform swivel movement and an exhaust-air-damped approach to the stop position are ensured.

6.5. Rough adjustment of the shock absorbers for universal swivel units



With the rough adjustment of the shock absorbers for universal swivel units, the "soft" or alternatively "hard" range of the inertia chart can be pre-set as a function of the cycle time, and the permissible cycles per hour can also be set. It is possible to set one end position to "hard" and the other end position to "soft". All universal swivel units are delivered in a "hard" condition as a standard feature. A rough adjustment is not possible for swivel units with – MV –. The shock absorber setting uses an additional adjusting piston in the stop piston.

The following work steps must be carried out for rough adjustment of the end position damping when the swivel unit is not pressurised.

- Screw off the protective cap ①
- Unscrew the mounting screw ② of the end position setting assembly. ③
- Carefully put the end position setting assembly ③ out of the body of the swivel unit.
- Use the driver to move the steering rack ④ to the desired end position by means of a pin wrench.
- Use circlip pliers for inner rings to remove the circlip ⑤
- Pull the shock absorber ⑥ out of the steering rack ④
- Depending on the previous setting, remove the adjusting washer ⑦ from the shock absorber hole (shims must always remain on the bottom of the shock absorber hole)
- For a "hard" range, position the adjusting washer ⑦ behind the shock absorber ⑥ (put the adjusting washer into the shock absorber hole first)
- For a "soft" range, position the adjusting washer ⑦ in front of the shock absorber ⑥ (put the adjusting washer into the shock absorber hole after the shock absorber)
- Mount the circlip ⑤ by means of circlip pliers for inner rings (make sure there is no play in the fit of the shock absorber)
- Move the steering rack ④ to the opposite end position using the driver by means of a pin wrench.
- Carefully push the end position setting assembly ③ into the body of the swivel unit.
- Use mounting screws ② to screw the end position setting assembly ③ onto the body of the swivel unit.
- Remove people, all tools and other objects from the operating range of the swivel unit.
- Connect the swivel unit to the power supply and fill it with suitably conditioned air.
- Open the set screws of the throttle check valves by a few turns.
- Pressurise the swivel unit alternately with compressed air.
- Check the setting and seat tightness of the interface between the end position setting and body.
- Screw on the protective cap ①

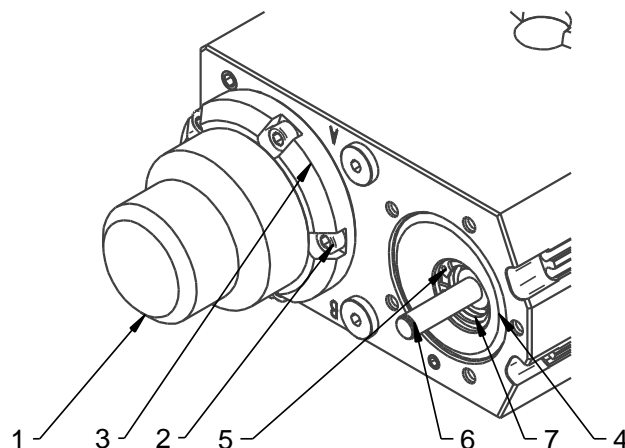

6.6. Piston chamber separation



Separation of the piston chambers can be carried out for all swivel units as a standard feature. The consequence of this is that the air consumption as well as the torque are cut in half. Piston chambers A and B may be separated independently of each other. That way it is possible to save the consumption of air.

The following work steps must be carried out for piston chamber separation when the swivel unit is not pressurised.

- Separation of piston chamber A:
 - Unscrew the threaded pin ① from the body of the swivel unit.
 - Screw the threaded pin ② from the accessories kit into the internal threaded hole as far as it goes
 - Use the threaded pin ① to reseal the external hole in the body of the swivel unit
- Separation of piston chamber B:
 - Same procedure as described under "Separation of piston chamber A"

Schnitt A-A

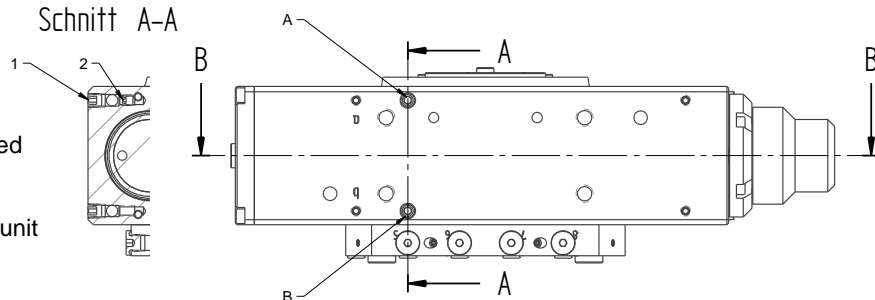

Schnitt B-B

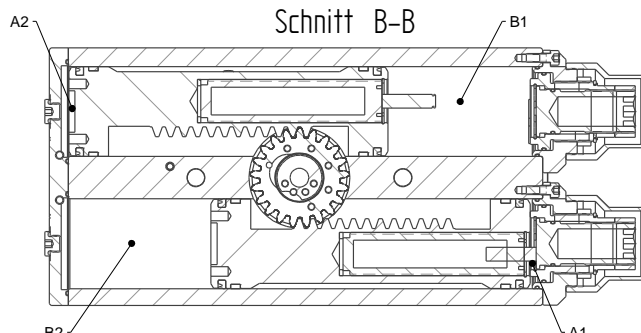

6.7. Swivel unit with fluid feeder

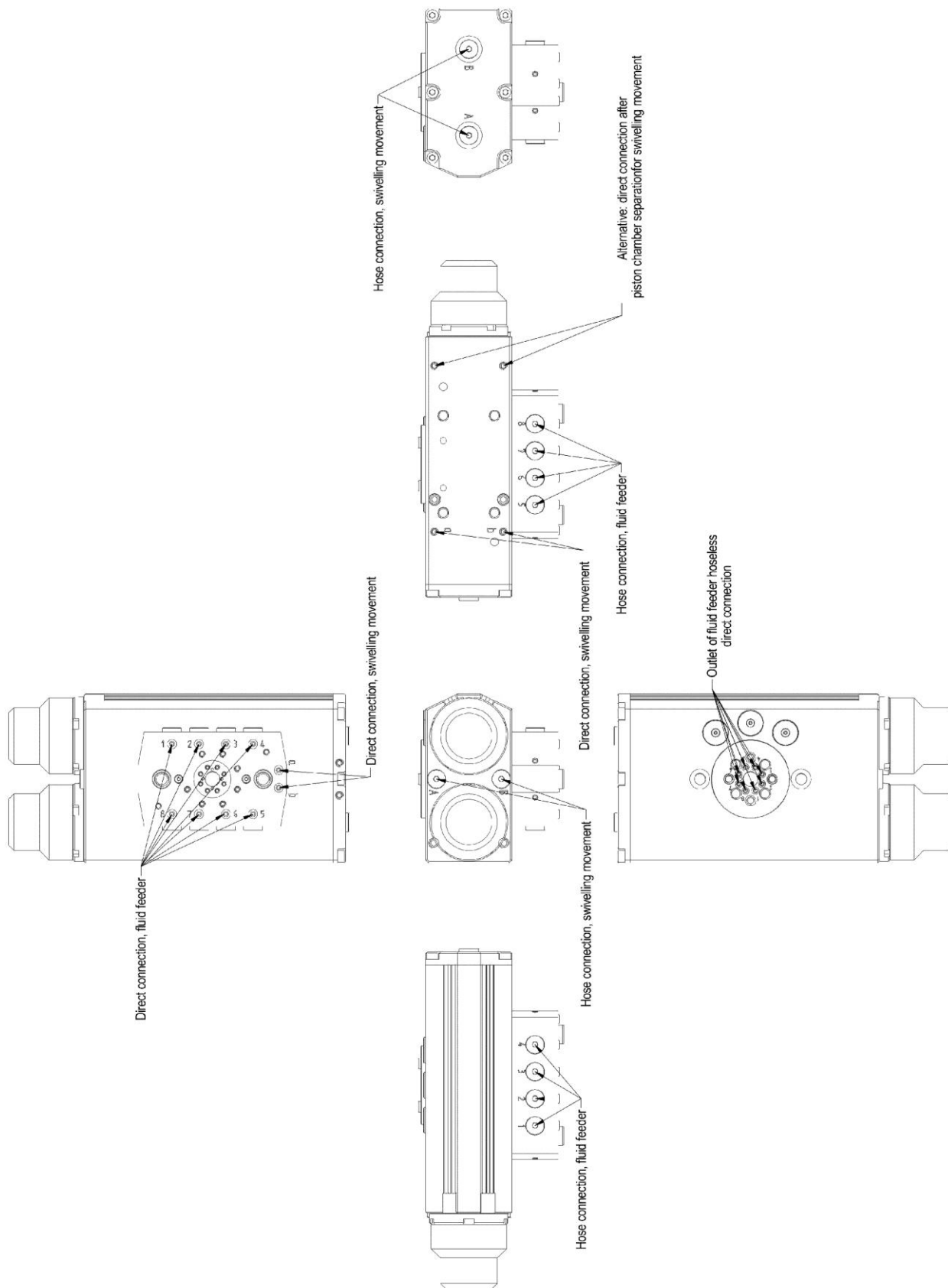

Id. 1250746



The connections shown for swivel movements apply to all sizes of the RSP series. The dimensions and tolerances can be found in the drawings provided in the internet.

6.8. Swivel units with fluid feeder and cable feed-through

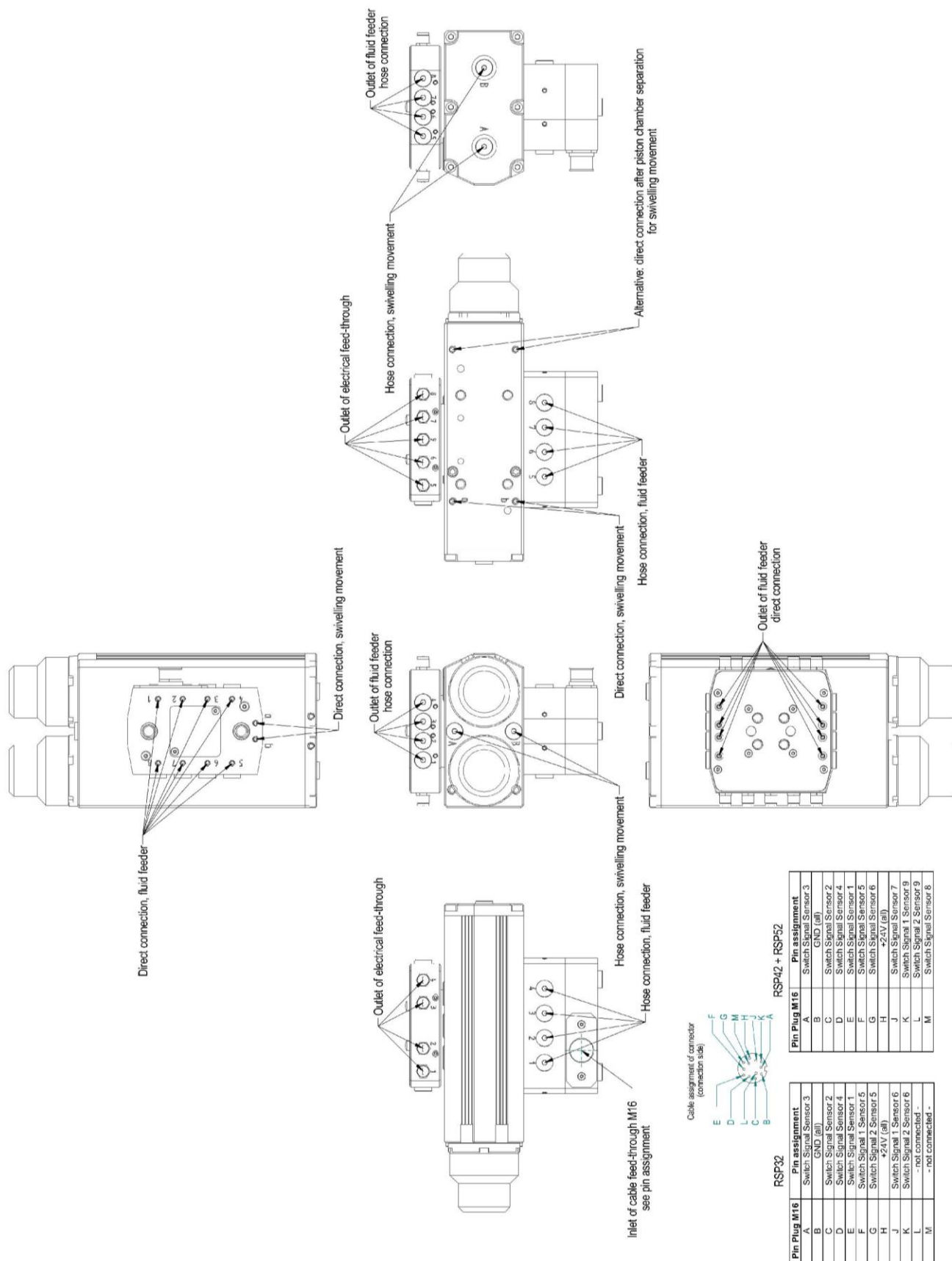

Id. 1250746



The connections shown for swivel movements apply to all sizes of the RSP series. The dimensions, tolerances, pin assignment and position of the electrical outlets can be found in the drawings provided in the internet.

7. Locked centre position

7.1. Function

Swivelling is identical to the description given in section 3. This version has a mechanical and shock-absorbed fixed stop in every position. The centre position is realised by means of two stop pistons. The mechanical dead stop in the centre position is created via a locking mechanism that is pushed by the locking piston onto the angular surface of the adjusting sleeve. It is unlocked by controlling a separate valve. If this valve is vented, then the locking is induced automatically. Hence, if the pressure drops, the locked position of the stop piston is ensured.

7.2. Schematic

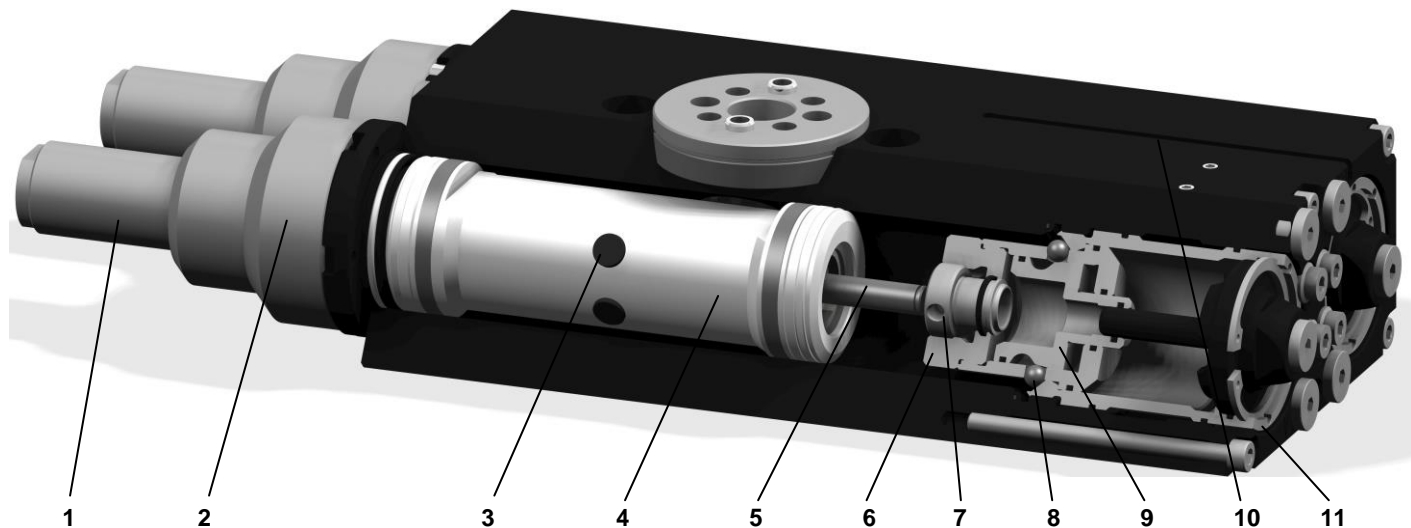

1. Shock absorber end position
2. End position adjustment
3. Magnet for determining the position
4. Steering rack
5. Shock absorber centre position
6. Stop centre position with magnet
7. Shock absorber adjustment centre position
8. Locking elements
9. Locking piston
10. Magnetic field sensor query stop centre position
11. End position adjustment centre position

7.3. Control



To be able to ensure flawless operation of the swivel unit, the sensors must be set as exactly as possible to the respective switching point.

7.3.1. Pneumatic connection diagram



The connection diagram here shows front hose-connected control of the swivel unit using the connections designated for that purpose.

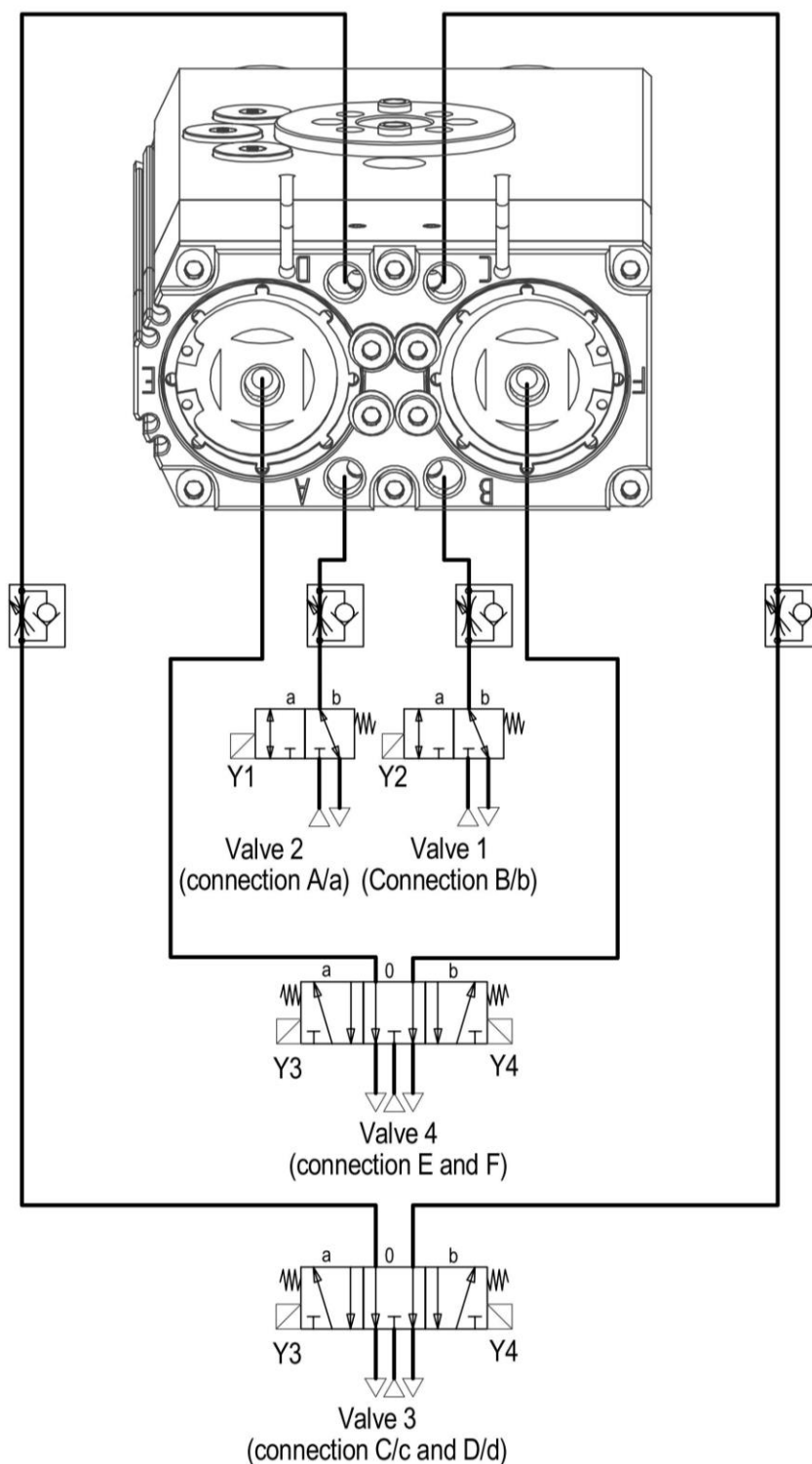

7.4. Path step charts

The path step charts shown in the following show swivelling movements (1) to (16). The swivelling movements that are shown are each dependent on the preceding swivelling movement.

Here, it must be differentiated from which position the centre position is being run into and whether the centre position will be passed over or only hit.

In step 4, for example, the centre position was passed over. In steps 13 and 15, on the other hand, the centre position was only hit in the preceding step.

The consequence is different control of what looks like the same swivelling movement.



Control of the unit that does not correspond to the specified sequence may lead to its destruction!

7.4.1. Difference between 6x or alternatively 5x and 4x or alternatively 3x sensor query

Path step chart with 6x or alternatively 5x sensor query (RECOMMENDED)

With the **6x sensor query**, an exact query can be carried out of the two end positions at 0° and 180°, the two 90° positions (0°-90° and 180°-90°) as well as the related stop pistons.

The **5x sensor query** determines the position of the two end positions at 0° and 180° of the stop pistons as well as a 90° range. This type of query can be used if either a 90° position is needed or if both 90° positions will be used. For use of both 90° positions, there is an overlap of the signals because of the design.

Path step chart with 4x or alternatively 3x sensor query (RECOMMENDED CONDITIONALLY)

The **4x sensor query** determines the two end positions at 0° and 180° as well as the 90° positions, once coming from 0° and once from 180°.

The **3x sensor query** determines the two end positions at 0° and 180°, however only one 90° range or alternatively one 90° position.

Both query possibilities are less process reliable and should be avoided.



The given times are for an operating pressure of 6 bar, a line length of 3m and a line diameter of 6mm determined empirically. The consequence of different operating conditions is that these times change.

The given times refer to the charts shown in section 7.3.1 to 7.3.4.

t1	0.2 sec	t2	0.1 sec	t3	0.1 sec
t4	0.1 sec	t5	0.1 sec	t6 min	0.5 sec

The given minimum time t6 refers to the 4x or alternatively 5x sensor query with optimum conditions of use. This time may be longer depending on the application. This time must be corrected for changed or alternatively complicated process conditions.

7.4.2. Path step chart query using 6 or alternatively 5 sensors

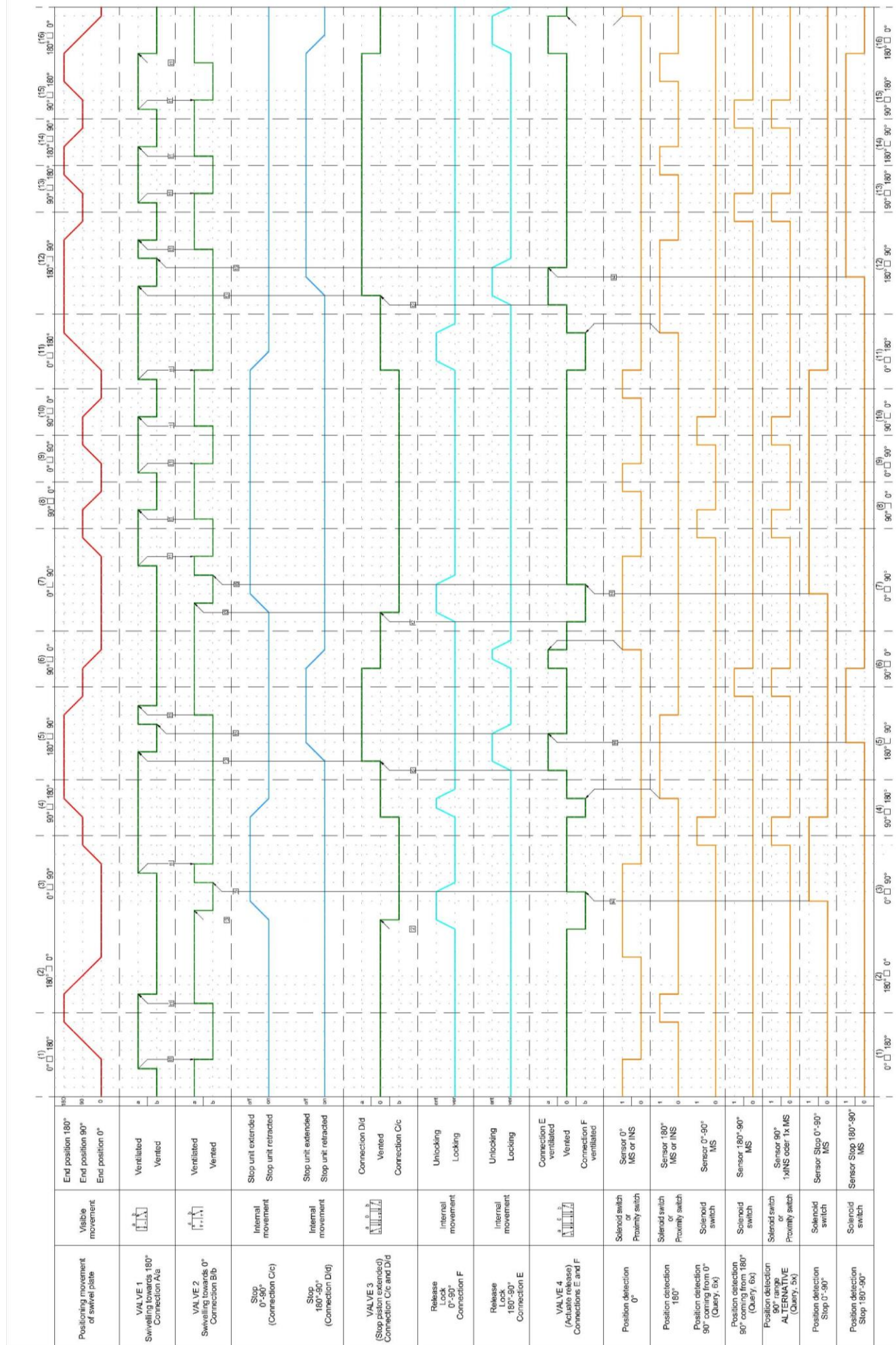

7.4.3. Path step chart query using 4 or alternatively 3 sensors

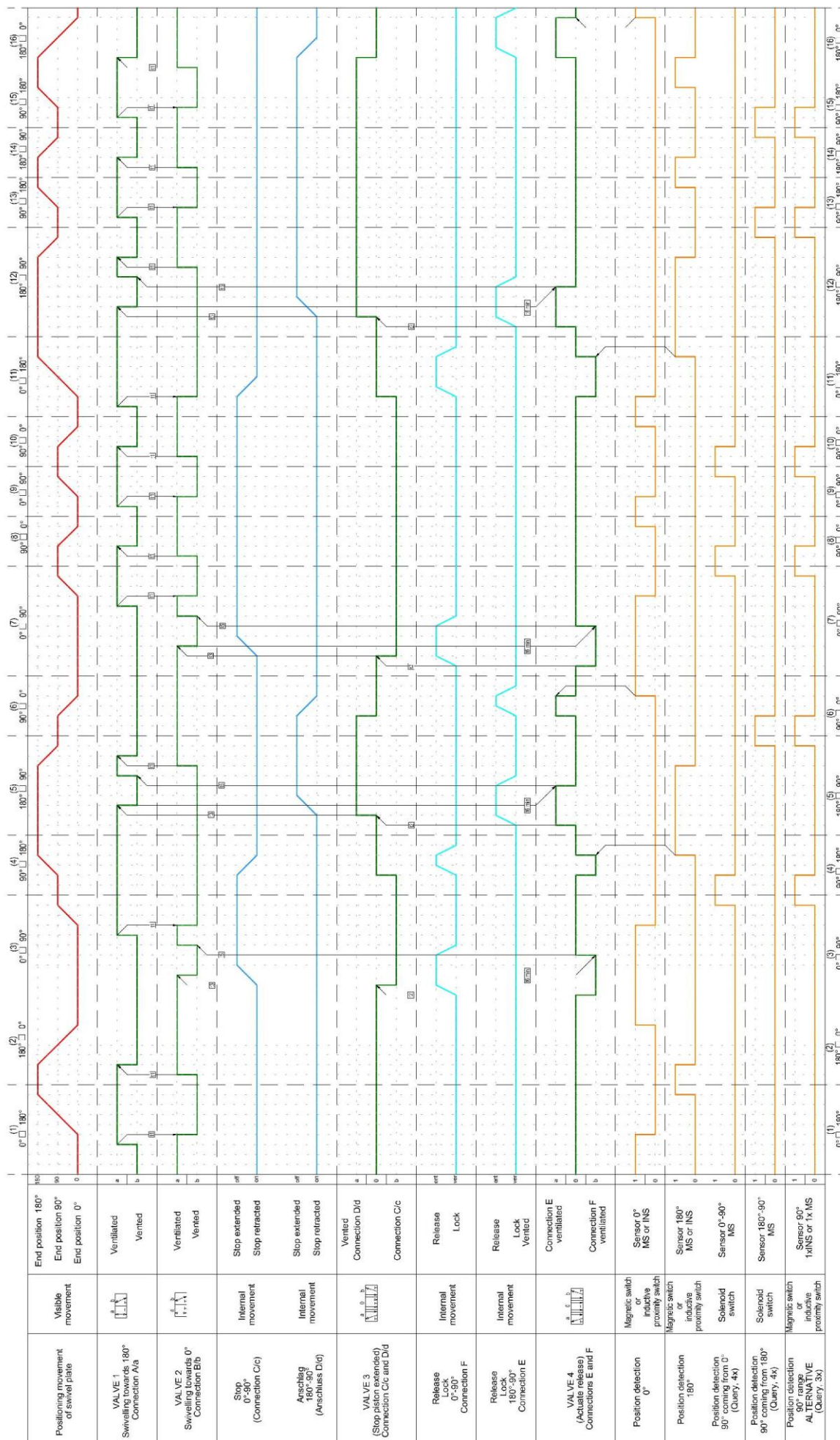

7.5. Control using S7 programming module



The function modules shown in the following are suitable exclusively for programming with Siemens STEP7 and are available in versions V5.4 and V5.5. (Other programming languages possible on request)
 The internal programming sequences are reduced to a minimum so that you only have to decide which end position has to be hit and when.

7.5.1. Illustration of the programming modules as FUP

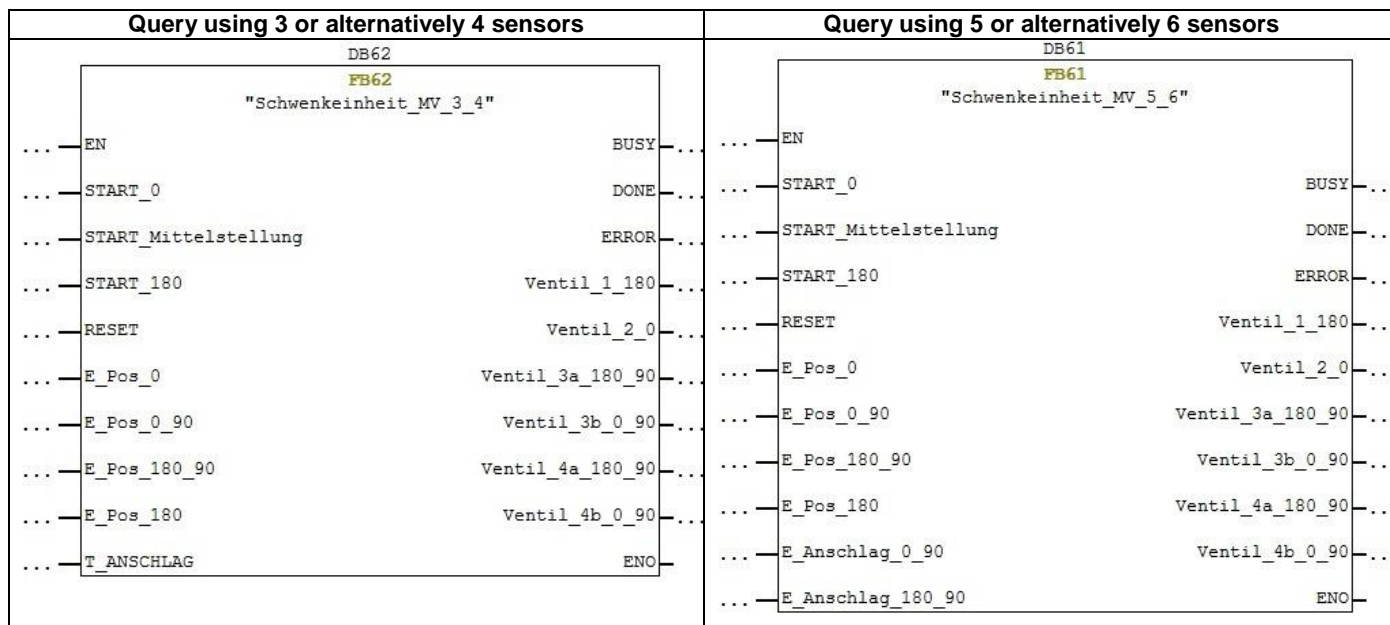

7.5.2. Explanation of the variables

INPUTS

START_0	Start swivel movement at the 0° position
START_MITTELSTELLUNG	Start swivel movement at the centre position (independent of from 0° or alternatively 180°)
START_180	Start swivel movement at the 180° position
RESET	Reset internal process of FB
E_POS_0	Position sensor 0°
E_POS_0_90	Position sensor 90° coming from 0°
E_POS_180_90	Position sensor 90° coming from 180°
E_POS_180	Position sensor 180°
E_Anschlag_0_90	Query stop piston 90° coming from 0° (only for 5x and 6x sensor query)
E_Anschlag_180_90	Query stop piston 90° coming from 180° (only for 5x and 6x sensor query)
T_Anschlag	Extension and locking time of the stop pistons (only for 3x and 4x sensor query).



If only one sensor is used to determine the position of the centre position, then the two input variables E_POS_0_90 and E_POS_180_90 have to be supplied with the same input signal.

OUTPUTS

BUSY	Swivelling movement currently being executed
DONE	Selected end position reached
ERROR	Incorrect control (e.g. 2x the same end position one after the other or signal path not correct)
Ventil_1_180	Valve 1 for swivelling movements in 180° direction
Ventil_2_0	Valve 2 for swivelling movements in 0° direction
Ventil_3a_180_90	Valve 3, position a for extension of the stop piston for 90° coming from 180°
Ventil_3b_0_90	Valve 3, position b for extension of the stop piston for 90° coming from 0°
Ventil_4a_180_90	Valve 4, position a for unlocking the stop piston for 90° coming from 180°
Ventil_4b_0_90	Valve 4, position b for unlocking the stop piston for 90° coming from 0°



The delivered data storage medium contains the modules with the 3x/4x and 5x/6x sensor query on the one hand, as well as a completely set-up sample project in which the control and integration are shown in customer-specific program sequences as an example.

7.5.3. Signal path of the module



When a move command (e.g. START_0) is set, then the positive flank of the BUSY signal comes. If the selected end position is reached (the 0° position in the shown example), then the positive flank of DONE appears. BUSY and DONE remain active until the move command (START_0 here) is reset. Only then is a move command to another end position possible. The valve control remains active until another move command is called or the module is reset by the RESET function.

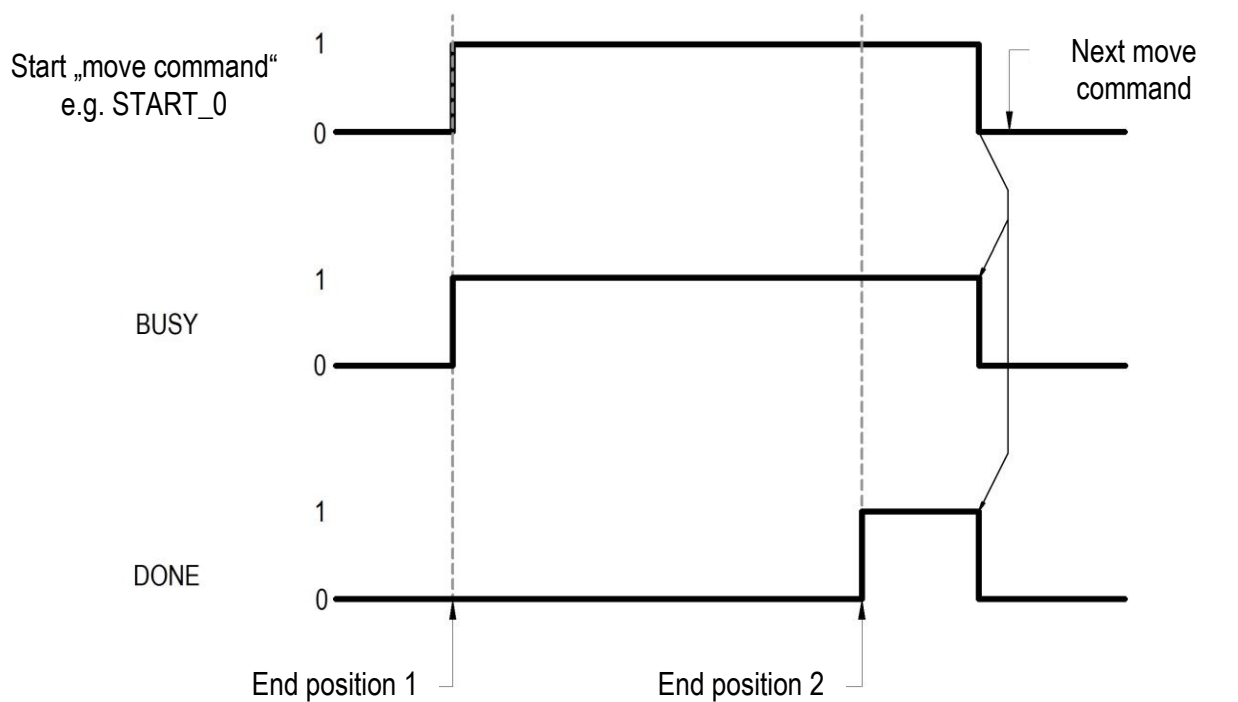

Other explanations of control and assignment are found on the data storage medium in the sample project.

7.6. Adjusting the end position of the centre position



When adjusting the centre position, only move towards the stop piston with the steering rack for which the side of the steering rack, on which the shock absorber protrudes, faces the stop piston. Failure to observe this may destroy the swivel unit. Tightening the lock screw too much may lead to the destruction or deformation of the lock screws.

The following work steps must be carried out for adjusting the end position:

- Remove people, tools and other objects from the danger zone of the swivel unit.
- Ventilate the unit
- Extend and lock the stop piston to be adjusted.
- Turn the swivel plate by hand as far as it goes.
- Unscrew the lock screws ① of the adjusting sleeve of the centre position by means of an Allen wrench.
- Use a pin wrench ② and the existing face pins to adjust the stop in the range of +/- 3°.
- Tighten the lock screws ① so they are finger tight.
- Repeat the procedure for the second stop.
- Remove people, tools and other objects from the danger zone of the swivel unit.
- Ventilate the unit and carry out a functional check.

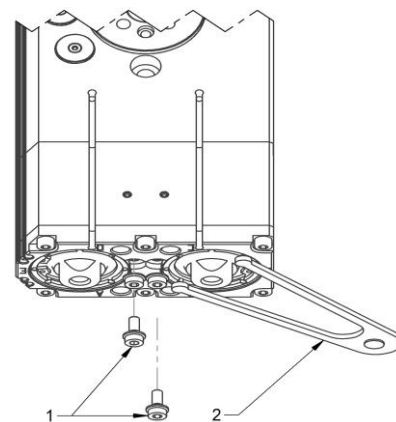

7.7. Adjusting the end position damping of the centre position



CAUTION! Failure to heed this information may lead to minor injuries

When transporting the unit to its final destination, the locally applicable occupational safety laws concerning lifting and carrying heavy loads must be observed.



WARNING! Failure to heed this information may lead to death or serious injuries

For overhead installation of a swivel unit and the related assemblies with deadweight of more than 3 kg, the work must be performed with a lifting mechanism or with two persons.

The following work steps must be carried out for adjusting the damping of the centre position and are shown using the end position of 90° coming from 0° as an example:

- Position the swivel unit to the 0° end position.
- Actuate the release (connection E).
- Extend stop piston 0°-90° (connection C) and lock (vent connection E).
- Keep the stop piston (connection C) under constant pressure during the adjustment.
- Detach hose connection E.
- Use an Allen wrench (SW 3 for RSP32, SW 4 for RSP42 and RSP52) to screw the adjusting piston in or out (screwing in increases the damping effect; screwing out decreases the damping effect).
- Remove the Allen wrench.
- Remove people, all tools and other objects from the operating range of the swivel unit.
- Ventilate the unit and carry out a functional check.
- When the functional check has been completed successfully, re-attach hose connection E.
- Actuate the release (connection E) and vent the stop (connection C).
- Swivel to the 180° position and adjust end position 90° coming from 180° with the same procedure as just described.

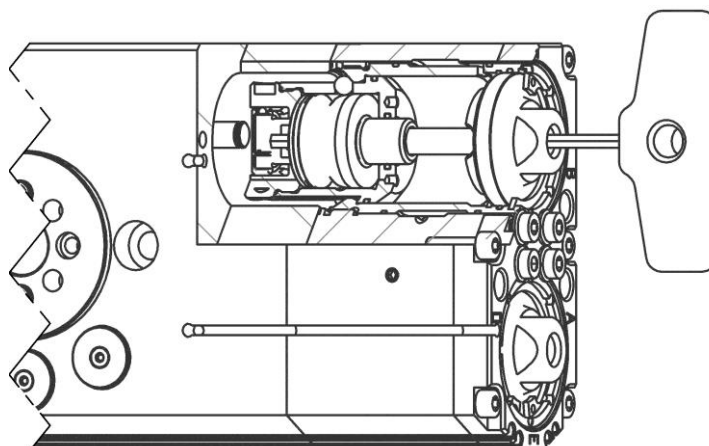

Because of the design, slight rattling will be noticed when screwing the shock absorber adjustment to the centre position. If the resistance increases when turning the wrench, then the entire stroke has been utilised. To prevent the piston from sticking, the piston must be turned at least two clicks in the opposite direction.

8. Maintenance

8.1. Information on possible dangers during maintenance

CAUTION! Failure to heed this information may lead to minor injuries

When transporting the unit to its final destination, the locally applicable occupational safety laws concerning lifting and carrying heavy loads must be observed.

8.2. Maintenance intervals

Maintenance-free operation of the swivel unit is guaranteed in a framework of up to 5 million cycles.

The maintenance interval may be less under the following conditions:

- operation with compressed air that does not comply with DIN ISO 8573-1 quality class 4
- dirty environment
- use that is improper and not in compliance with the performance data
- ambient temperature above 60°C, lubricants harden sooner

At each maintenance the swivel unit must be greased with the following or demonstrably equivalent lubricant:

- Klüberplex BEM 41-132

8.3. Disassembling the swivel unit

It is recommended to have the maintenance and seal replacement carried out by the RÖHM GmbH repair service. There may be complications during unauthorised disassembly and reassembly of the swivel unit, because special installation devices are required in part.

9. Fault repair

Fault	Possible causes	Fault repair
Swivel unit does not move	Minimum pressure undershot	Increase operating pressure
	Throttle closed (condition at delivery)	Slowly open throttle until the desired swivel time is reached
	Incorrect hose connections	Check the compressed air hoses and connections
	Unneeded air connections open	Professionally seal air connections
	Sensors defective or set incorrectly	Check sensors and wiring and replace if necessary
	Weight of the attachments or alternatively workpieces too high	Compare the weights to the technical data of the swivel unit
	Damage to one or more functional parts from overload	Disassemble the swivel unit; replace damaged parts; re-grease and replace gaskets
Swivel unit moves with a jerky motion	Not enough grease in the mechanical glide surfaces	Clean and re-lubricate the swivel unit
	Minimum pressure undershot	Increase operating pressure
	Operating pressure throttled too much	Slowly open throttles until the desired effect is achieved
	Weight of the attachments or alternatively workpieces too high	Compare the weights to the technical data of the swivel unit
	Venting phases not observed for centre position units	Revise the program flow
End positions not reached	Dirt deposits between the stop and steering rack	Remove the end position setting assembly. Clean and re-lubricate the module
	The end positions are misaligned	Readjust the end positions
	Minimum pressure undershot	Check air supply
	Modules have become loose, from overloading for example	Disassemble the swivel unit; replace damaged parts; re-grease and replace gaskets
	Shock absorber defective	Check shock absorbers. Replace if necessary
End positions are hit too hard.	Wrong damping range set for universal swivel units	Check the mass properties of the customer-specific application once again. If necessary, change the rough setting of the shock absorber hardness in the steering rack.
	Settings of end position damping incorrect	Screw the adjusting piston in completely and then readjust
	Settings of the end position damping for swivel units with locked centre position incorrect	Unscrew the shock absorber of the end position setting assembly completely, perform a functional check, screw it back in completely and readjust
	Shock absorber defective	Unscrew the shock absorber, readjust it and check the damping behaviour

Torque not reached	Minimum pressure undershot	Increase operating pressure
	Gaskets overflow	Disassemble the unit, replace gaskets and re-grease
	Too much grease on the moving components	Disassemble the unit, clean, re-grease and replace gaskets
Centre position not reached	Programming error	Compare the controller to the control plan
	Incorrect hose connections	Check the compressed air hoses and connections
	Minimum pressure undershot	Increase operating pressure
	Weight or alternatively TM of the attachments or alternatively workpieces too high	Compare the weights to the technical data of the swivel unit
	Damage to one or more functional parts from overloading	Disassemble the swivel unit; replace damaged parts; re-grease and replace gaskets

10. Accessories / delivery contents



The function of the swivel unit cannot be guaranteed if accessories are used that are not sold or authorised by RÖHM GmbH. The RÖHM GmbH range of accessories is customised specifically for the individual swivel units. The throttle check valves found in the accessories kit must be used under all circumstances. If that is not possible, then an equivalent valve must be installed. If the swivel unit is operated without throttling, then the warranty becomes void.

Accessories that are optional and contained in the delivery contents can be found at www.roehm.biz.

11. Sensors

11.1. Information on using sensors



To ensure process-reliable querying, the sensors must be used that are sold by RÖHM GmbH and listed as a recommended accessory for the respective swivel unit. RÖHM GmbH does not guarantee the function if third party products are used.

Exposing sensors to an additional external magnetic field, such as the field created by servo motors, may result in switching point displacements.

The sensors sold by RÖHM GmbH with an casted cable are all drag-chain compatible.

The minimum permissible installation radius is 5-times the diameter of the cable. For rigid installation, this radius is reduced to 3-times the cable diameter.

11.2. Setting the magnetic field sensors

11.2.1. General



During the installation of the magnetic field sensors by means of a conventional Allen wrench, there will be a displacement of the magnetic field due to the material properties and hence to a switching point displacement.

When testing the signal, remove the Allen wrench.

A displacement of the magnetic field can also arise from attachments with ferritic properties, which makes it necessary to readjust the magnetic field sensors.



WARNING! Failure to heed this information may lead to death or serious injuries

Before actuation of the swivel unit, make sure that no body parts are in the positioning range of the swivel unit. The swivel unit can still move after an EMERGENCY STOP.

The following work steps must be carried out to install and start-up the magnetic field sensors:

- Move the swivel unit to one of the end positions while it is not pressurised.
- Energise magnetic field sensor, insert into the C-groove that exists on the swivel unit, slide up to the first switching point (LED on) and mark the point.
- Continue sliding the magnetic field sensor up to the switch-off point (LED off), slide back until the second switching point (LED on) is reached and mark that point.
- The optimum position of the magnetic field sensor is between the two switching points.
- Observe the maximum tightness of the mounting screw(s). See the datasheet of the magnetic field sensor.
- The procedure must be repeated for the other end positions.

11.2.2. Swivel unit with locked centre position and query using 6 magnetic field sensors



To be able to accurately detect the 90° end position, we recommend querying the 90° end position with two magnetic field sensors. One sensor is for the query coming from the end position at 0° and one sensor is for the query coming from the end position at 180°.



WARNING! Failure to heed this information may lead to death or serious injuries

Before actuation of the swivel unit, make sure that no body parts are in the positioning range of the swivel unit. The swivel unit can still move after an EMERGENCY STOP.

The following work steps must be carried out to install and start-up the magnetic field sensors:

- End positions 0° and 180°, sensors 0° and sensor 180°
 - Procedure as given in 11.2.1
- Sensor stop 0°-90°, position swivel unit to 0° end position
 - Insert magnetic field sensor in C-groove and slide as far as it goes.
 - Extend the stop piston (pressure connection D) and lock (pressure connection F)
 - Slide magnetic field sensor in the direction of the arrow until the switching signal appears (LED illuminates)
 - Slide magnetic field sensor minimally further in the direction of the arrow after detecting the signal (LED illuminates).
 - Functional check by passing over the centre position multiple times. Adjust if necessary.
- Sensor stop 180°-90°, position swivel unit to 180° end position
 - Same procedure as just described for sensor stop 180°-90°, however coming from 180° with pressure connection A (stop piston) and pressure connection E (release)
- Sensor 0°-90°, driver at 0° position, extend stop piston and lock (pressure connections C and F) and turn the steering rack via the driver by means of the pin wrench to the 90° position (90° position coming from 0°)
 - Insert the magnetic field sensor into the C-groove on the end of the body opposite to the direction of the arrow.
 - Slide the magnetic field sensor in the direction of the arrow until the switching signal appears (LED illuminates)
 - Slide the magnetic field sensor ca. 1 mm further in the direction of the arrow after detecting the signal (LED illuminates).
 - Functional check by hitting the end position multiple times. Adjust if necessary.
- Sensor 180°-90°, driver at 180° position, extend stop piston and lock (pressure connections D and E) and turn the steering rack via the driver by means of the pin wrench to the 90° position (90° position coming from 0°)
 - Insert the magnetic field sensor into the C-groove on the end of the body opposite to the direction of the arrow.
 - Slide the magnetic field field sensor in the direction of the arrow until the switching signal appears (LED illuminates)
 - Slide the magnetic field sensor ca. 1 mm further in the direction of the arrow after detecting the signal (LED illuminates).
 - Functional check by hitting the end position multiple times. Adjust if necessary.

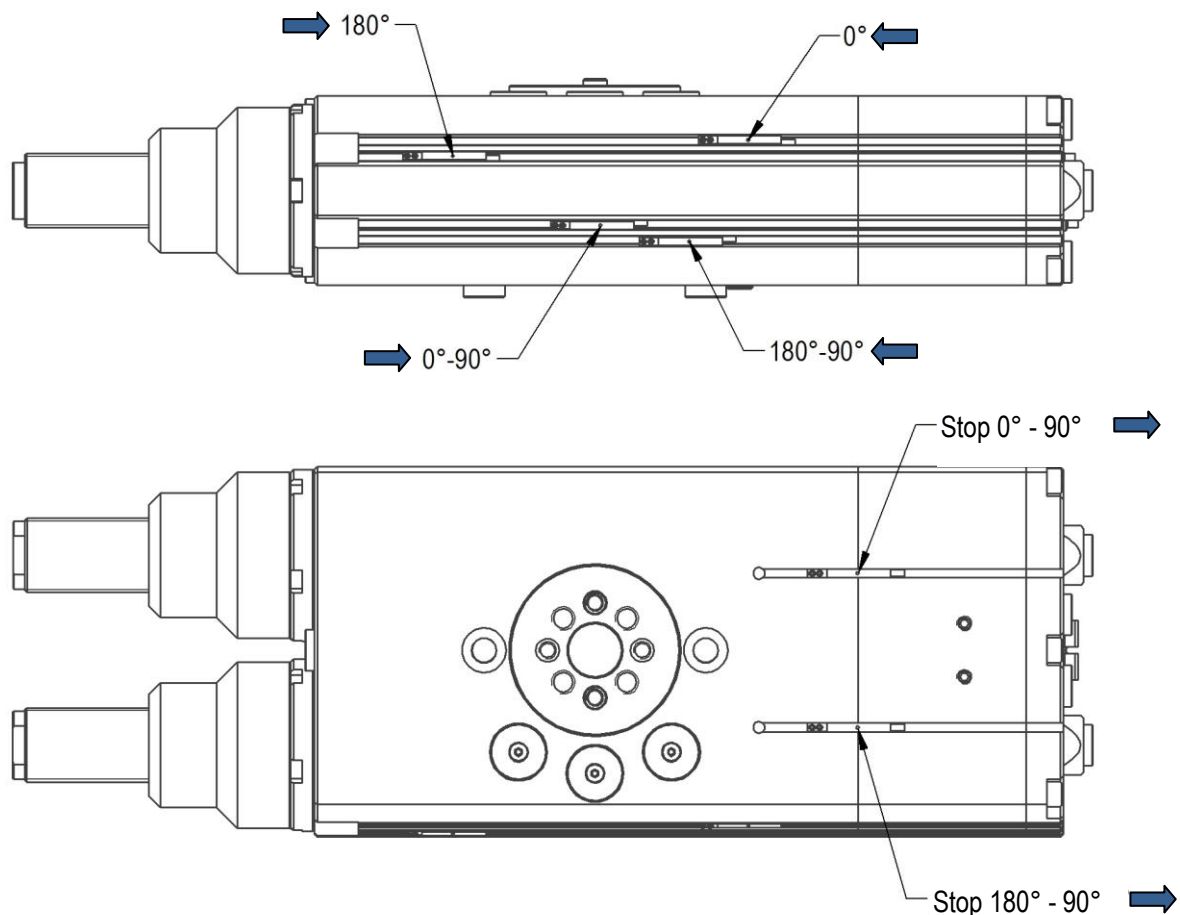



The positions of the magnetic field sensors shown in the drawing correspond approximately to the actual positions at start-up. Set the stop sensors as accurately as possible.

11.3. Setting the inductive sensors



The prerequisite for using inductive sensors is to attach the external sensor holders as well as the intermediate plate that contains the trip cams for signal detection. These components are part of the "Inductive add-on kit" accessory and are not part of the delivery contents of the unit. The "Inductive add-on kit" is available for swivel units with and without a fluid feeder. For swivel unit with a cable feed-through, there is the possibility to obtain this add-on kit as an option to the order. The inductive sensors are not contained in the delivery contents of the add-on kit.



WARNING! Failure to heed this information may lead to death or serious injuries

Before actuation of the swivel unit, make sure that no body parts are in the positioning range of the swivel unit. The swivel unit can still move after an EMERGENCY STOP.

The following work steps must be carried out to install and start-up the inductive sensors:

- Move the swivel unit to the 0° end position without it being pressurised.
- Remove the cover plate ①
- At the place where the cover plate was located, screw the sensor holder ② lightly into the opening
- Use the centring sleeve from the accessories kit of the swivel unit to put the intermediate plate ③ on the driver (secure with screw to driver if necessary)
- For a swivel unit with fluid feeder, first of all place the O-rings from the accessories kit of the swivel unit on the openings of the driver designated for that purpose.
- Push the trip cams into the intermediate plate ③ (there are small notches for rough orientation; the notches do not apply for swivel units with – MV –)
 - Long trip cams ④ for 0° and 180° end position
 - Short trip cams ⑤ for 90° end position
- Roughly align the trip cams ④+⑤ on the notches and secure them lightly with an Allen wrench
- Put the sensor ⑦ (not included in the delivery contents) in the sensor holder ② as far as it goes
- Energise the sensor ⑦
- Screw in the set screw ⑥ of the sensor holder ② using an Allen wrench until the switching signal appears and a safe switching distance is ensured (LED illuminates)
- The sensor ⑦ must always be on the abutment of the set screw ⑥
- Screw in the set screw ⑥ to a maximum of up to 1 mm from the trip cam
- Secure the sensor ⑦ with the two clamping screws
- Adjust the trip cams ④ if necessary and then secure with an Allen wrench.
- Clamp the sensor holder ②
- The procedure must be repeated for the other end positions.
- Before testing the query with a pressurised swivel unit, it must be ensured that the swivelling movement will take place without the trip cams bumping the sensor holders.
- Remove people, all tools and other objects from the operating range of the swivel unit.
- Ventilate the unit and carry out a functional check.

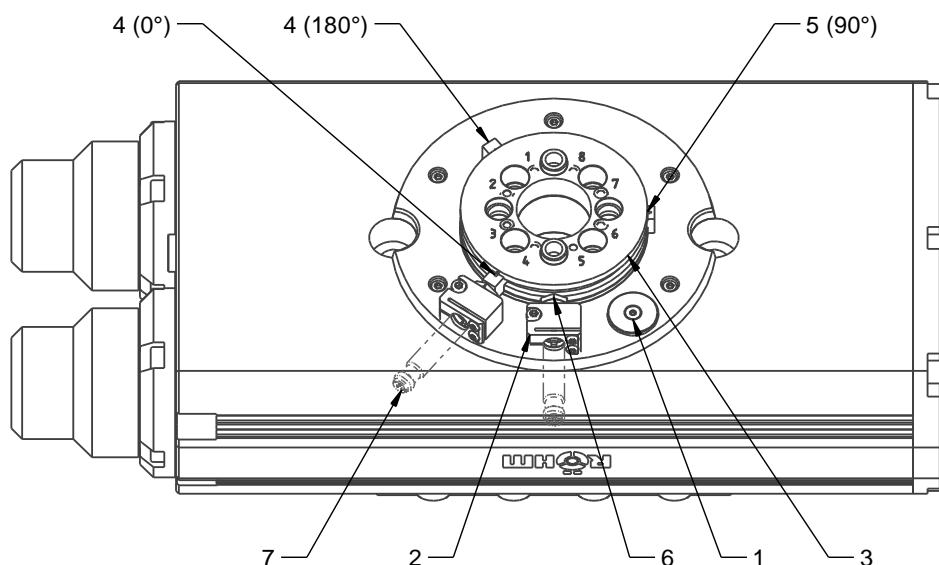

12. Declaration of incorporation



Erklärung für den Einbau einer unvollständigen Maschine

Im Sinne der Richtlinie 2006/42/EG für Maschinen, Anhang II, Teil B

Hiermit erklärt die RöhM GmbH / Werk Dillingen
RöhMstraße 6
D-89407 Dillingen/Donau
Deutschland

für folgendes Produkt:

<u>Fabrikat:</u>	PNEUMATISCH BET. SCHWENKEINHEIT
<u>Typenbezeichnung:</u>	TYP: RSP32-52
<u>Baujahr:</u>	ab 2014

dass die folgenden grundlegenden Anforderungen der o. g. Richtlinie - einschließlich der zum Zeitpunkt dieser Erklärung gültigen Änderungen - zur Anwendung kommen und eingehalten wurden:

EN ISO 12100-1 Sicherheit von Maschine – Grundbegriffe, allgemeine Gestaltungsleitsätze, - Teil 1: Grundsätzliche Terminologie, Methodik

EN ISO 12100-2 Sicherheit von Maschine – Grundbegriffe, allgemeine Gestaltungsleitsätze, - Teil 2: Technische Leitsätze und Spezifikationen

dass die speziellen technischen Unterlagen gemäß Anhang VII Teil B der o. g. Richtlinie erstellt wurden und den einzelstaatlichen Stellen auf begründetes Verlangen wie folgt übermittelt werden:

In Papierform **oder** in Dateiform per E-Mail

dass diese unvollständige Maschine erst dann in Betrieb genommen werden darf, wenn festgestellt wurde, dass die Maschine, in welche die unvollständige Maschine eingebaut werden soll, den Bestimmungen der o. g. Richtlinie entspricht.

Person, die in der Gemeinschaft ansässig und bevollmächtigt ist, die technischen Unterlagen zusammenzustellen:

Name: Wiedholz, Gerhard Anschrift: RöhM GmbH, Werk Dillingen, RöhMstr. 6, 89407 Dillingen

Ausstellungsort: Dillingen
Ausstellungsdatum: 23.04.2014
Funktion des Unterzeichners im Unternehmen: Konstruktionsleiter
Name des Unterzeichners: Gerhard Wiedholz

RöhM GmbH
Werk Dillingen
RöhMstraße 6
89407 Dillingen/Donau
Tel. 09071/508-0

Unterschrift: i. V. 

Blatt 1/1